

APPROVED DATE: June 20, 2003

DIRECTOR, DEPARTMENT OF ENGINEERING
AND TECHNICAL SERVICES

REVISION NO.: 0
DATE: 6/20/03
PREPARED BY: OBG/BKJV
CHECKED BY: W.DARROW

STANDARD DETAIL
DUCTILE IRON SEWER
PIPE LAYING CONDITION TYPE 2A
(TRENCH INSTALLATION)

PIPE DIAMETER D	TRENCH PAY WIDTH	
	UNSHEETED (W _u)	SHEETED (W _s)
8"	2' - 10"	2' - 4"
12"	3' - 2"	2' - 8"
16"	3' - 6"	3' - 0"
20"	3' - 10"	3' - 4"
24"	4' - 2"	3' - 8"
30"	4' - 8"	4' - 2"
36"	6' - 1"	5' - 7"
42"	6' - 7"	6' - 1"
48"	7' - 1"	6' - 7"

NOTES:

1. PIPE LAYING CONDITION TYPE 2A (TRENCH INSTALLATION) SHALL BE USED FOR ALL DUCTILE IRON PIPE SEWER CONSTRUCTION UNLESS OTHERWISE SPECIFIED.

2. TRENCHES MAY BE EXCAVATED WIDER THAN THE TRENCH PAY WIDTH (W_s OR W_u) ABOVE A LINE 1'-0" FROM TOP OF PIPE, AT CONTRACTOR'S OPTION AND AT NO ADDITIONAL COST TO THE AUTHORITY.

3. IF EXCAVATION TO A DEPTH GREATER THAN 4.5 FEET IS REQUIRED, EXCAVATION SUPPORT SHEETING MAY BE ORDERED OR TRENCH SHIELDS UTILIZED AT CONTRACTORS OPTION. COSTS UNDER THIS OPTION SHALL BE PART OF THE UNIT PIECE BID FOR EXCAVATION.

4. SHEETING, IF USED, SHALL BE REMOVED IN CONJUNCTION WITH THE BACKFILLING OPERATION UNLESS OTHERWISE SPECIFIED OR SHOW ON DRAWINGS. HOWEVER, IF APPROVED IN WRITING, SHEETING MAY BE CUT-OFF AND LEFT IN PLACE BELOW A LINE 1'-0" ABOVE THE TOP OF PIPE OR AS DIRECTED BY THE ENGINEER.

APPROVED DATE: June 20, 2003

DIRECTOR, DEPARTMENT OF ENGINEERING
AND TECHNICAL SERVICES

REVISION NO.: 0
 DATE: 6/20/03
 PREPARED BY: OBG/BKJV
 CHECKED BY: W.DARROW

STANDARD DETAIL
 DUCTILE IRON SEWER
 PIPE LAYING CONDITON TYPE 2A
 (TRENCH INSTALLATION)

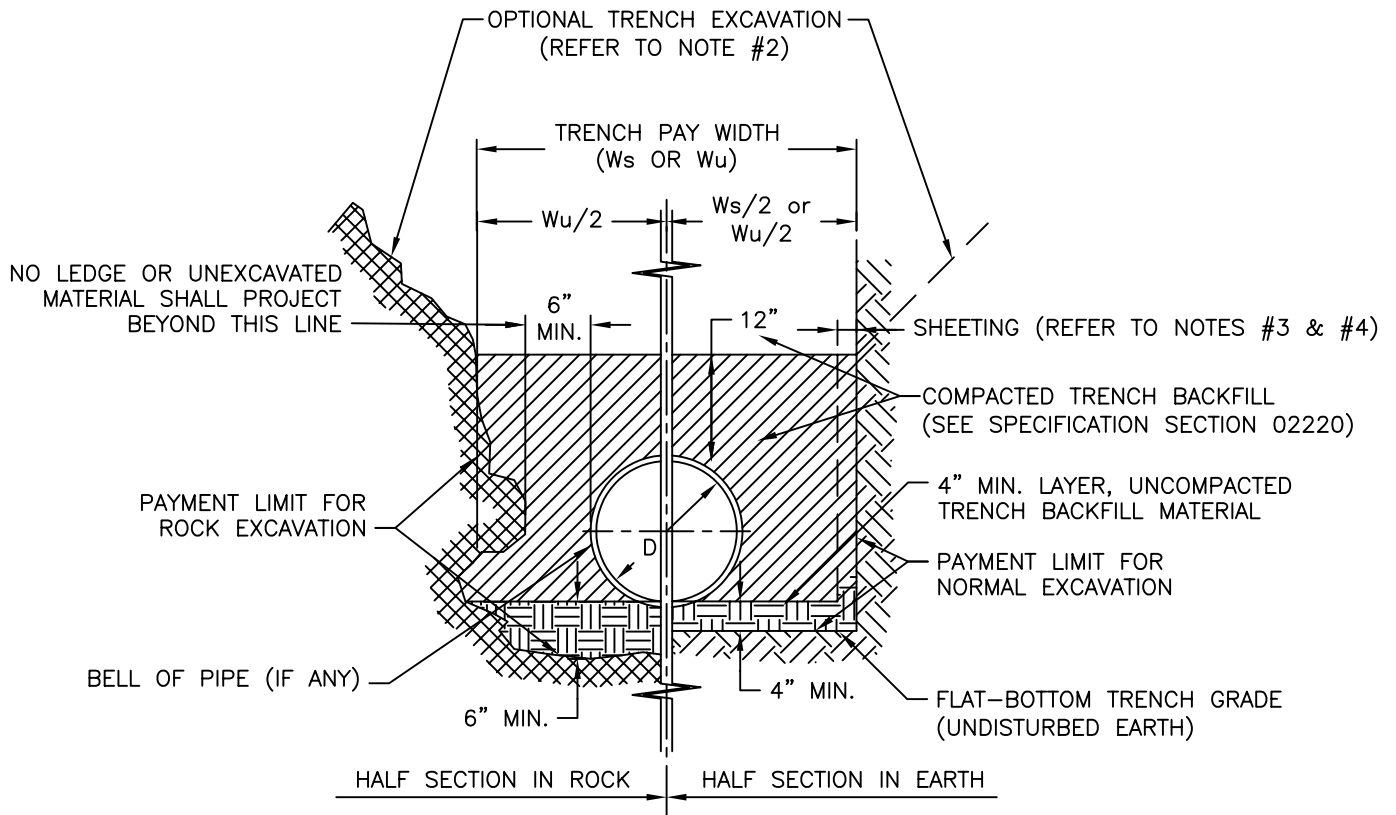

APPROVED DATE: June 20, 2003

DIRECTOR, DEPARTMENT OF ENGINEERING
AND TECHNICAL SERVICES

REVISION NO.: 0
DATE: 6/20/03
PREPARED BY: OBG/BKJV
CHECKED BY: W.DARROW

STANDARD DETAIL
DUCTILE IRON SEWER
PIPE LAYING CONDITION TYPE 3A
(TRENCH INSTALLATION)

PIPE DIAMETER D	TRENCH PAY WIDTH (Ws or Wu)	
	UNSHEETED (Wu)	SHEETED (Ws)
8"	2' - 4"	2' - 10"
12"	2' - 8"	3' - 2"
16"	3' - 0"	3' - 6"
20"	3' - 4"	3' - 10"
24"	3' - 8"	4' - 2"
30"	4' - 2"	4' - 8"
36"	5' - 7"	6' - 1"
42"	6' - 1"	6' - 7"
48"	6' - 7"	7' - 1"

NOTES:

1. PIPE LAYING CONDITION TYPE 3A (TRENCH INSTALLATION) SHALL BE USED FOR DUCTILE IRON PIPE SEWER CONSTRUCTION ONLY WHEN SPECIFIED OR SHOWN ON DRAWINGS.
2. TRENCHES MAY BE EXCAVATED WIDER THAN THE TRENCH PAY WIDTH (Ws OR Wu) ABOVE A LINE 1'-0" FROM TOP OF PIPE, AT CONTRACTOR'S OPTION AND AT NO ADDITIONAL COST TO THE AUTHORITY.
3. IF EXCAVATION TO A DEPTH GREATER THAN 4.5 FEET IS REQUIRED, EXCAVATION SUPPORT SHEETING MAY BE ORDERED OR TRENCH SHIELDS UTILIZED AT CONTRACTORS OPTION. COSTS UNDER THIS OPTION SHALL BE PART OF THE UNIT PRICE BID FOR EXCAVATION.
4. SHEETING, IF USED, SHALL BE REMOVED IN CONJUNCTION WITH THE BACKFILLING OPERATION UNLESS OTHERWISE SPECIFIED OR SHOWN ON DRAWINGS. HOWEVER, IF APPROVED IN WRITING, SHEETING MAY BE CUT-OFF AND LEFT IN PLACE BELOW A LINE 1'-0" ABOVE THE TOP OF PIPE OR AS DIRECTED BY THE ENGINEER.

APPROVED DATE: June 20, 2003

DIRECTOR, DEPARTMENT OF ENGINEERING
AND TECHNICAL SERVICES

REVISION NO.: 0
DATE: 6/20/03
PREPARED BY: OBG/BKJV
CHECKED BY: W.DARROW

STANDARD DETAIL
DUCTILE IRON SEWER
PIPE LAYING CONDITION TYPE 3A
(TRENCH INSTALLATION)

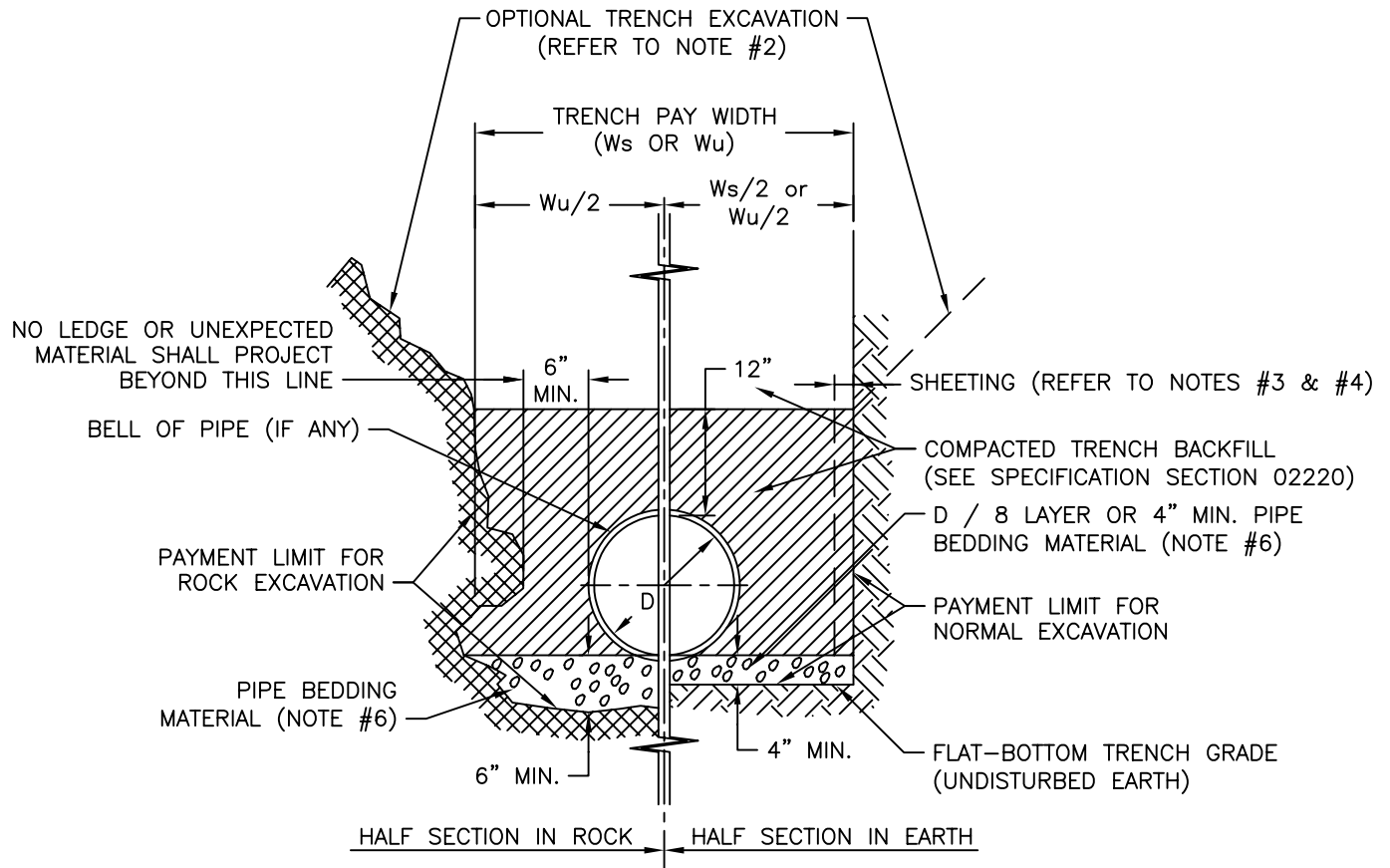

APPROVED DATE: June 20, 2003

DIRECTOR, DEPARTMENT OF ENGINEERING
AND TECHNICAL SERVICES

REVISION NO.: 0
DATE: 6/20/03
PREPARED BY: OBG/BKJV
CHECKED BY: W.DARROW

STANDARD DETAIL
DUCTILE IRON SEWER
PIPE LAYING CONDITION TYPE 4A
(TRENCH INSTALLATION)

PIPE DIAMETER D	TRENCH PAY WIDTH (Ws or Wu)	
	UNSHEETED (Wu)	SHEETED (Ws)
8"	2' - 4"	2' - 10"
12"	2' - 8"	3' - 2"
16"	3' - 0"	3' - 6"
20"	3' - 4"	3' - 10"
24"	3' - 8"	4' - 2"
30"	4' - 2"	4' - 8"
36"	5' - 7"	6' - 1"
42"	6' - 1"	6' - 7"
48"	6' - 7"	7' - 1"

NOTES:

1. PIPE LAYING CONDITION TYPE 4A (TRENCH INSTALLATION) SHALL BE USED FOR DUCTILE IRON PIPE SEWER CONSTRUCTION ONLY WHEN SPECIFIED OR SHOWN ON DRAWINGS.
2. TRENCHES MAY BE EXCAVATED WIDER THAN THE TRENCH PAY WIDTH (Ws OR Wu) ABOVE A LINE 1'-0" FROM TOP OF PIPE, AT CONTRACTOR'S OPTION AND AT NO ADDITIONAL COST TO THE AUTHORITY.
3. IF EXCAVATION TO A DEPTH GREATER THAN 4.5 FEET IS REQUIRED, EXCAVATION SUPPORT SHEETING MAY BE ORDERED OR TRENCH SHIELDS UTILIZED AT CONTRACTORS OPTION. COSTS UNDER THIS OPTION SHALL BE PART OF THE UNIT PRICE BID FOR EXCAVATION.
4. SHEETING, IF USED, SHALL BE REMOVED IN CONJUNCTION WITH THE BACKFILLING OPERATION UNLESS OTHERWISE SPECIFIED OR SHOWN ON DRAWINGS. HOWEVER, IF APPROVED IN WRITING, SHEETING MAY BE CUT-OFF AND LEFT IN PLACE BELOW A LINE 1'-0" ABOVE THE TOP OF PIPE OR AS DIRECTED BY THE ENGINEER.
5. COMPACTED TRENCH BACKFILL, 80 % BETWEEN PIPE BEDDING AND 12 INCHES ABOVE TOP OF PIPE.
6. PIPE BEDDING MATERIAL SHALL BE GRAVEL OR CRUSHED STONE CONFORMING TO ASTM C-33, GRADING SIZE NO. 67 OR NO. 57.

APPROVED DATE: June 20, 2003

DIRECTOR, DEPARTMENT OF ENGINEERING
AND TECHNICAL SERVICES

REVISION NO.: 0
DATE: 6/20/03
PREPARED BY: OBG/BKJV
CHECKED BY: W.DARROW

STANDARD DETAIL
DUCTILE IRON SEWER
PIPE LAYING CONDITION TYPE 4A
(TRENCH INSTALLATION)

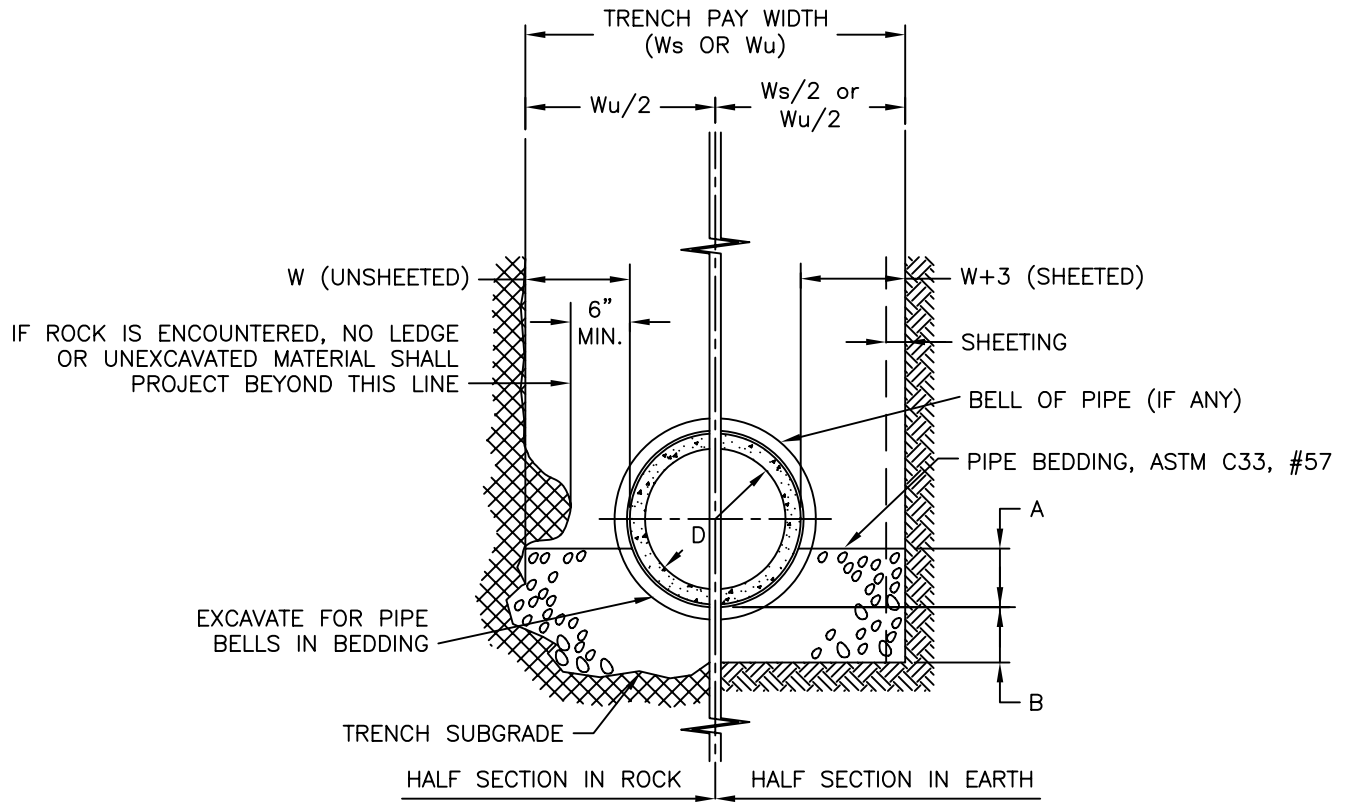

APPROVED DATE: June 20, 2003

DIRECTOR, DEPARTMENT OF ENGINEERING
 AND TECHNICAL SERVICES

REVISION NO.: 0
 DATE: 6/20/03
 PREPARED BY: OBG/BKJV
 CHECKED BY: W.DARROW

STANDARD DETAIL
 CONCRETE PIPE SEWER
 TRENCH LAYING CONDITION

PIPE DIAMETER D	PIPE BEDDING DIMENSION				TRENCH PAY WIDTH	
	W	A	B		UNSHEETED W _u	SHEETED W _s
			IN SOIL	IN ROCK		
12"	12"	5"	3"	6"	3' - 4"	3' - 10"
15"	12"	5"	3"	6"	3' - 7"	4' - 1"
18"	12"	6"	3"	6"	3' - 11"	4' - 5"
21"	12"	7"	3"	6"	4' - 3"	4' - 9"
24"	12"	8"	3"	6"	4' - 6"	5' - 0"
27"	18"	8"	3"	6"	5' - 9"	6' - 3"
30"	18"	9"	4"	9"	6' - 1"	6' - 7"
33"	18"	10"	4"	9"	6' - 5"	6' - 11"
36"	18"	10"	4"	9"	6' - 8"	7' - 2"
42"	18"	13"	4"	9"	7' - 3"	7' - 9"
48"	24"	15"	4"	9"	8' - 10"	9' - 4"
54"	24"	16"	4"	9"	9' - 5"	9' - 11"
60"	24"	18"	4"	9"	10' - 0"	10' - 6"
66"	24"	20"	6"	12"	10' - 7"	11' - 1"
72"	24"	22"	6"	12"	11' - 2"	11' - 8"
78"	24"	23"	6"	12"	11' - 9"	12' - 3"
84"	24"	25"	6"	12"	12' - 4"	12' - 10"
90"	24"	27"	6"	12"	12' - 11"	13' - 5"
96"	24"	28"	6"	12"	13' - 6"	14' - 0"
102"	24"	30"	6"	12"	14' - 1"	14' - 7"
108"	24"	32"	6"	12"	14' - 8"	15' - 2"

NOTES:

1. IF NECESSARY TO EXCEED W BELOW A HORIZONTAL PLANE 1'-0" ABOVE TOP OF PIPE, SEE SPECIFICATION SECTION 02220.
2. SHEETING, IF USED, SHALL BE REMOVED IN CONJUNCTION WITH THE BACKFILLING OPERATION UNLESS OTHERWISE SPECIFIED OR SHOWN ON DRAWING. HOWEVER, IF APPROVED IN WRITING, SHEETING MAY BE CUT-OFF AND LEFT IN PLACE BELOW A LINE 1'-0" ABOVE THE TOP OF THE PIPE OR AS DIRECTED BY THE ENGINEER.

APPROVED DATE: June 20, 2003

DIRECTOR, DEPARTMENT OF ENGINEERING
AND TECHNICAL SERVICES

REVISION NO.: 0
DATE: 6/20/03
PREPARED BY: OBG/BKJV
CHECKED BY: W.DARROW

STANDARD DETAIL
CONCRETE PIPE SEWER
TRENCH LAYING CONDITION

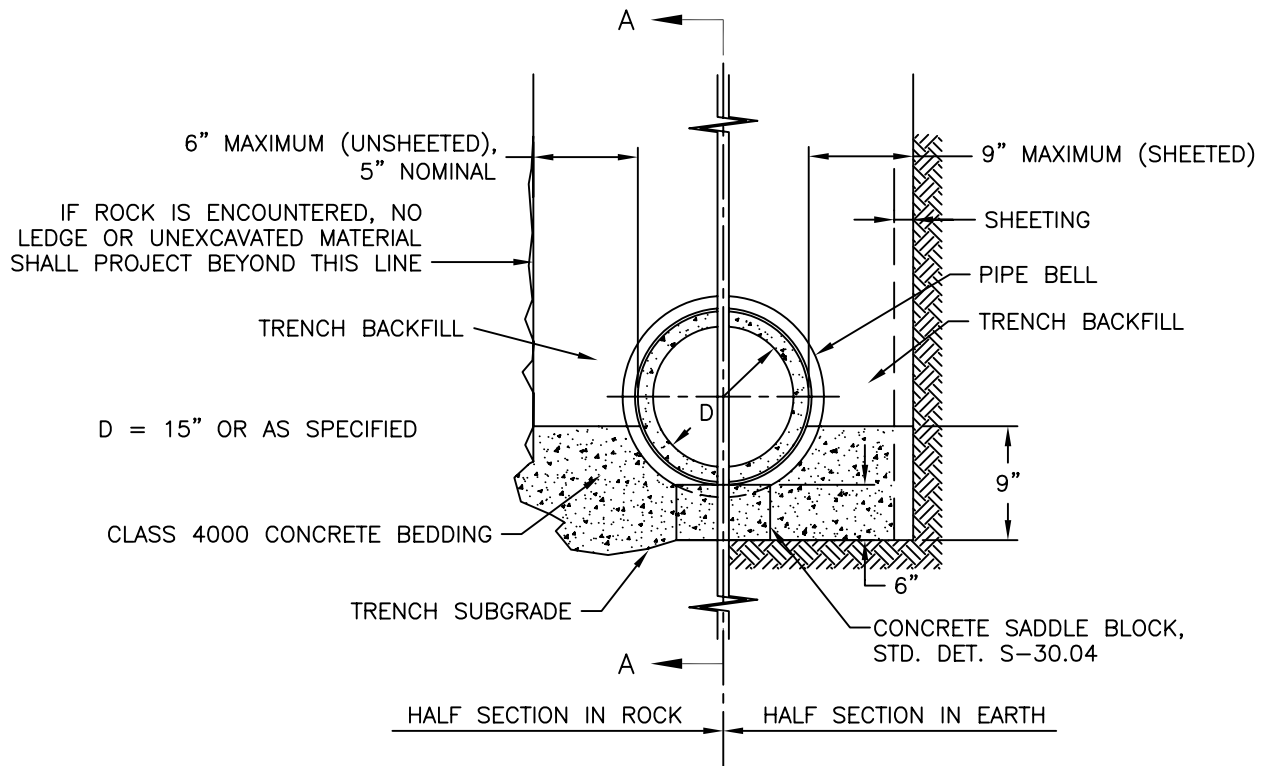

SADDLE BLOCKS - 2 PER STANDARD
PIPE LENGTH, NOT REQUIRED AT PIPE
ENTRY TO BASIN AND MANHOLE IF
PIPE IS INSTALLED AFTER BASIN
AND/OR SEWER MANHOLE

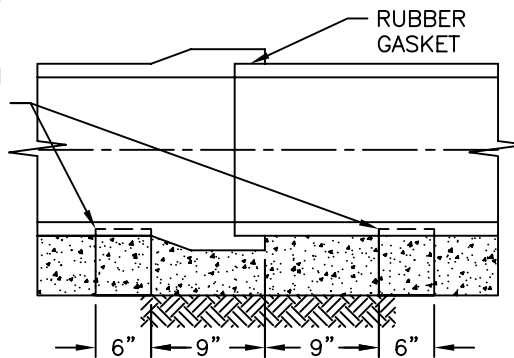

SECTION A - A

APPROVED DATE: June 20, 2003

DIRECTOR, DEPARTMENT OF ENGINEERING
AND TECHNICAL SERVICES

REVISION NO.: 0
DATE: 6/20/03
PREPARED BY: OBG/BKJV
CHECKED BY: W.DARROW

STANDARD DETAIL
CATCH BASIN CONNECTION PIPE
TRENCH LAYING CONDITION

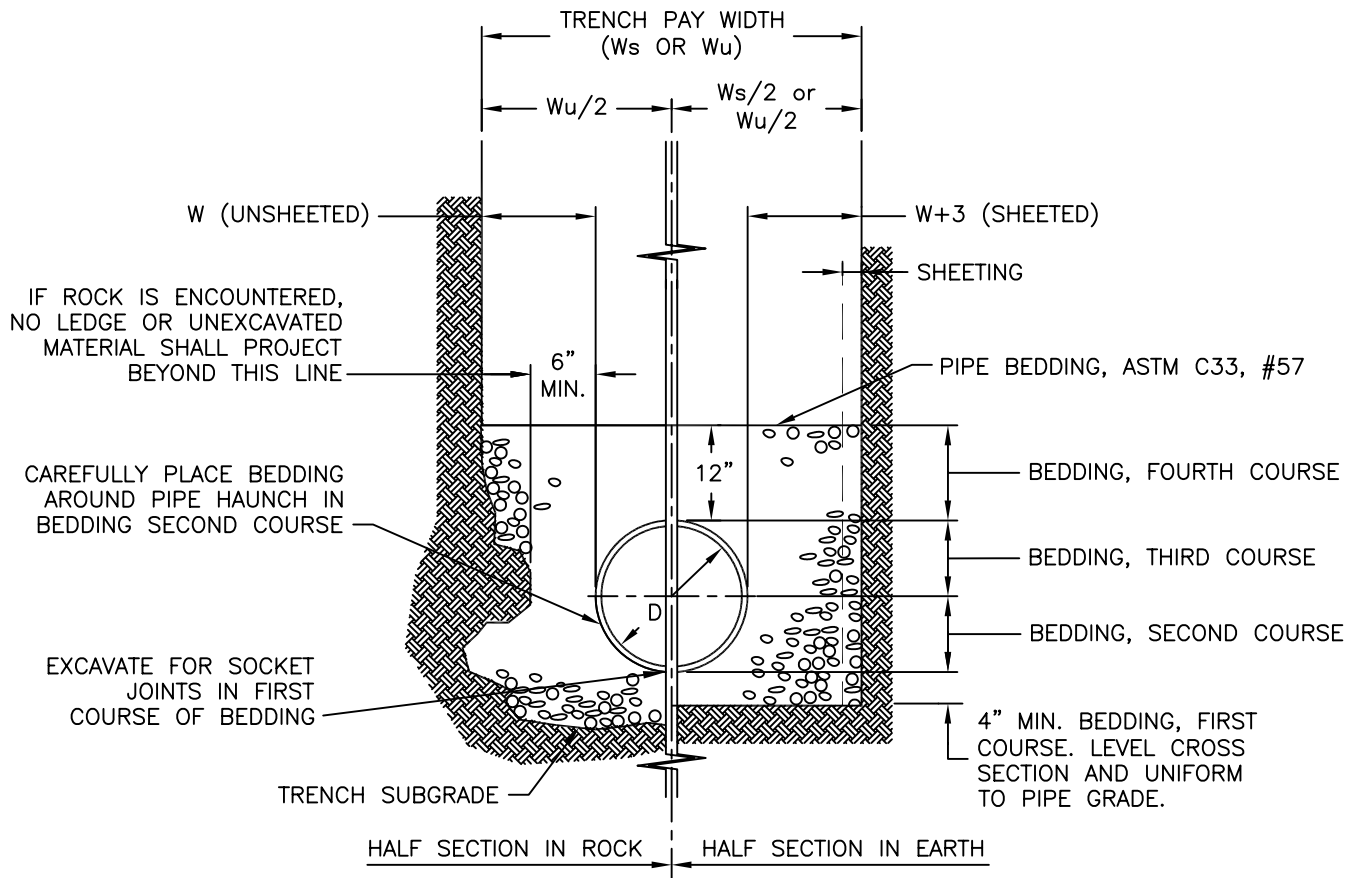

TRENCH PAY WIDTH (Ws OR Wu)			
PIPE DIAMETER D	TRENCH WIDTH CLEAR W	TRENCH PAY WIDTH	
		Wu	Ws
10"	12"	2'-11"	3'-5"
12"	12"	3'-0"	3'-6"
15"	12"	3'-3"	3'-9"
18"	12"	3'-7"	4'-1"
21"	12"	3'-10"	4'-4"
24"	12"	4'-1"	4'-7"
27"	12"	5'-4"	5'-10"

NOTES:

1. IF NECESSARY TO EXCEED W BELOW A HORIZONTAL PLANE 1'-0" ABOVE TOP OF PIPE, SEE SPECIFICATION SECTION 02220.
2. SHEETING, IF USED, SHALL BE REMOVED IN CONJUNCTION WITH THE BACKFILLING OPERATION UNLESS OTHERWISE SPECIFIED OR SHOWN ON DRAWING.

APPROVED DATE: June 20, 2003

DIRECTOR, DEPARTMENT OF ENGINEERING
AND TECHNICAL SERVICES

REVISION NO.: 0
DATE: 6/20/03
PREPARED BY: OBG/BKJV
CHECKED BY: W.DARROW

STANDARD DETAIL

POLYVINYL CHLORIDE (PVC) PIPE SEWER
TRENCH LAYING CONDITION

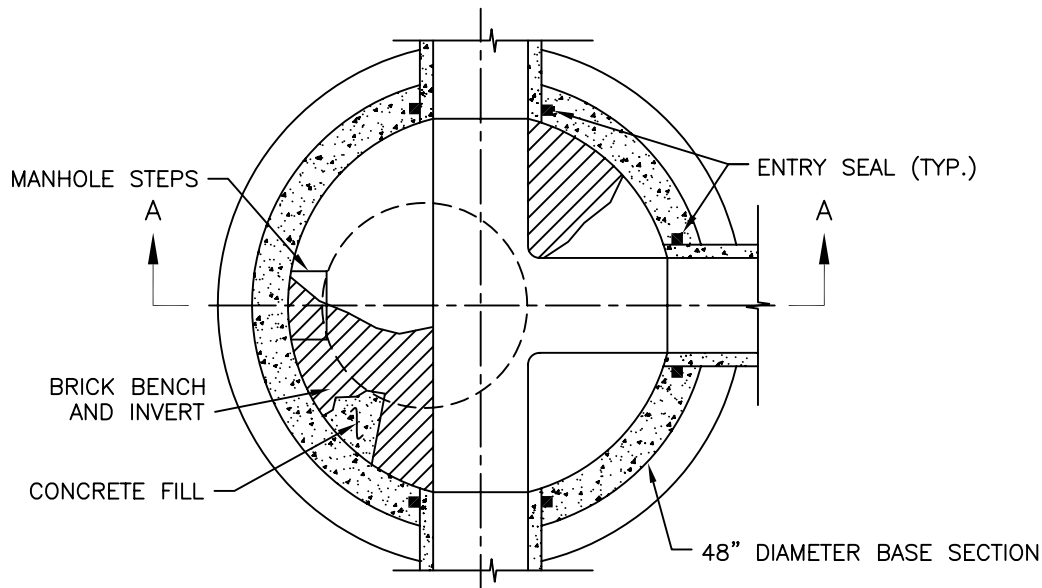

SECTIONAL PLAN

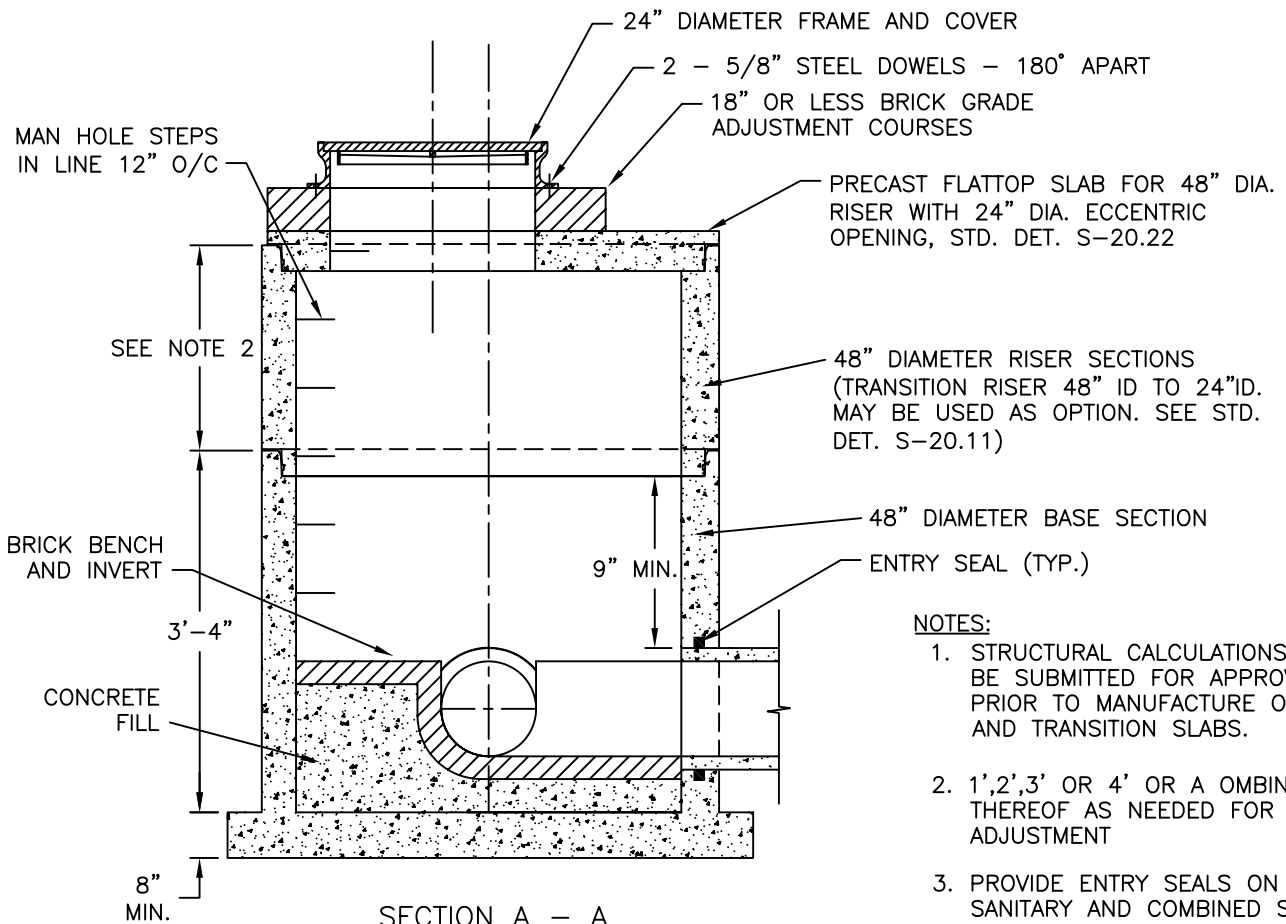

SECTION A - A

NOTES:

1. STRUCTURAL CALCULATIONS MUST BE SUBMITTED FOR APPROVAL PRIOR TO MANUFACTURE OF BASE AND TRANSITION SLABS.
2. 1', 2', 3' OR 4' OR A COMBINATION THEREOF AS NEEDED FOR GRADE ADJUSTMENT
3. PROVIDE ENTRY SEALS ON SANITARY AND COMBINED SEWER CONNECTIONS 24" AND SMALLER.

APPROVED DATE: June 20, 2003

DIRECTOR, DEPARTMENT OF ENGINEERING
AND TECHNICAL SERVICES

REVISION NO.: 0
DATE: 6/20/03
PREPARED BY: OBG/BKJV
CHECKED BY: W.DARROW

STANDARD DETAIL
PRECAST CONCRETE MANHOLE
FOR NEW 10" THRU 21" DIAMETER SEWERS
(48" DIAMETER PRECAST BASE)

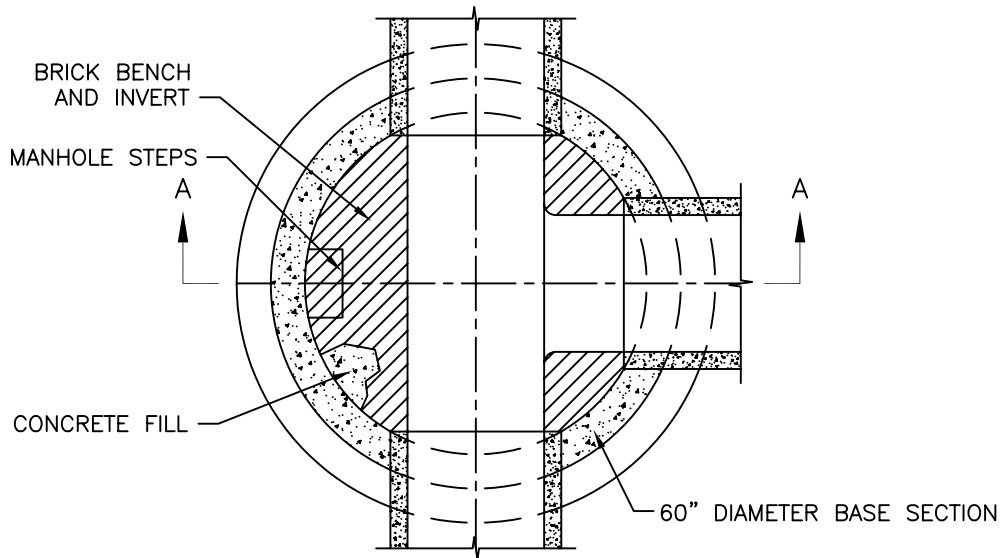

SECTIONAL PLAN

15' OR LESS TO INVERT
24" DIA. COVER WITH
36" X 24" DIA. ADAPTER RING

GREATER THAN 15' DEPTH
36" DIAMETER COVER

FOR DETAIL SEE
STD. DET. S-20.20

SEE
NOTE 2

MAN HOLE STEPS
IN LINE 12" O/C

BRICK BENCH
AND INVERT

5'-0"

CONCRETE FILL

8"
MIN.

36" DIAMETER FRAME

2 - 5/8" STEEL DOWELS - 180° APART

18" OR LESS BRICK GRADE
ADJUSTMENT COURSES

PRECAST FLATTOP SLAB FOR 48" DIA.
RISER WITH 36" DIA. ECCENTRIC
OPENING, STD. DET. S-20.23

48" DIAMETER RISER SECTIONS
(TRANSITION RISER 48" ID TO 24" ID.
MAY BE USED AS OPTION. SEE STD.
DET. S-20.11)

PRECAST SLAB FOR 60" DIA. RISER
WITH 48" DIA. ECCENTRIC OPENING,
STD. DET. S-20.24

60" DIAMETER BASE SECTION

9"
MIN.

NOTES:

1. STRUCTURAL CALCULATIONS MUST BE SUBMITTED FOR APPROVAL PRIOR TO MANUFACTURE OF BASE AND TRANSITION SLABS.
2. 1', 2', 3' OR 4' OR A COMBINATION THEREOF AS NEEDED FOR GRADE ADJUSTMENT
3. PROVIDE ENTRY SEALS ON SANITARY AND COMBINED SEWER CONNECTIONS 24" AND SMALLER.

SECTION A - A

APPROVED DATE: June 20, 2003

DIRECTOR, DEPARTMENT OF ENGINEERING
AND TECHNICAL SERVICES

REVISION NO.: 0
DATE: 6/20/03
PREPARED BY: OBG/BKJV
CHECKED BY: W.DARROW

STANDARD DETAIL
PRECAST CONCRETE MANHOLE
FOR NEW 24" THRU 30" DIAMETER SEWERS
(60" DIAMETER PRECAST BASE)

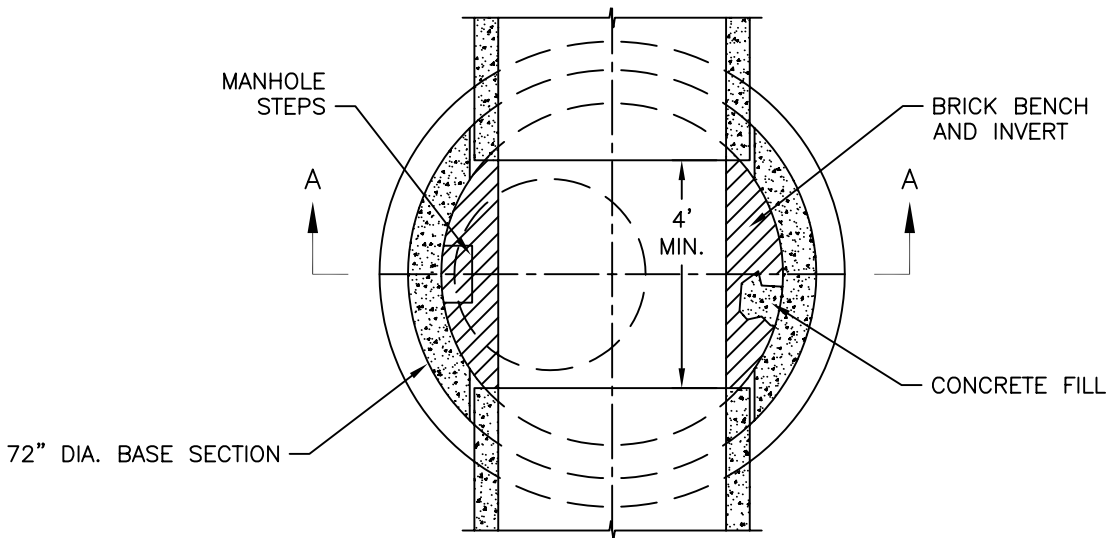

SECTIONAL PLAN

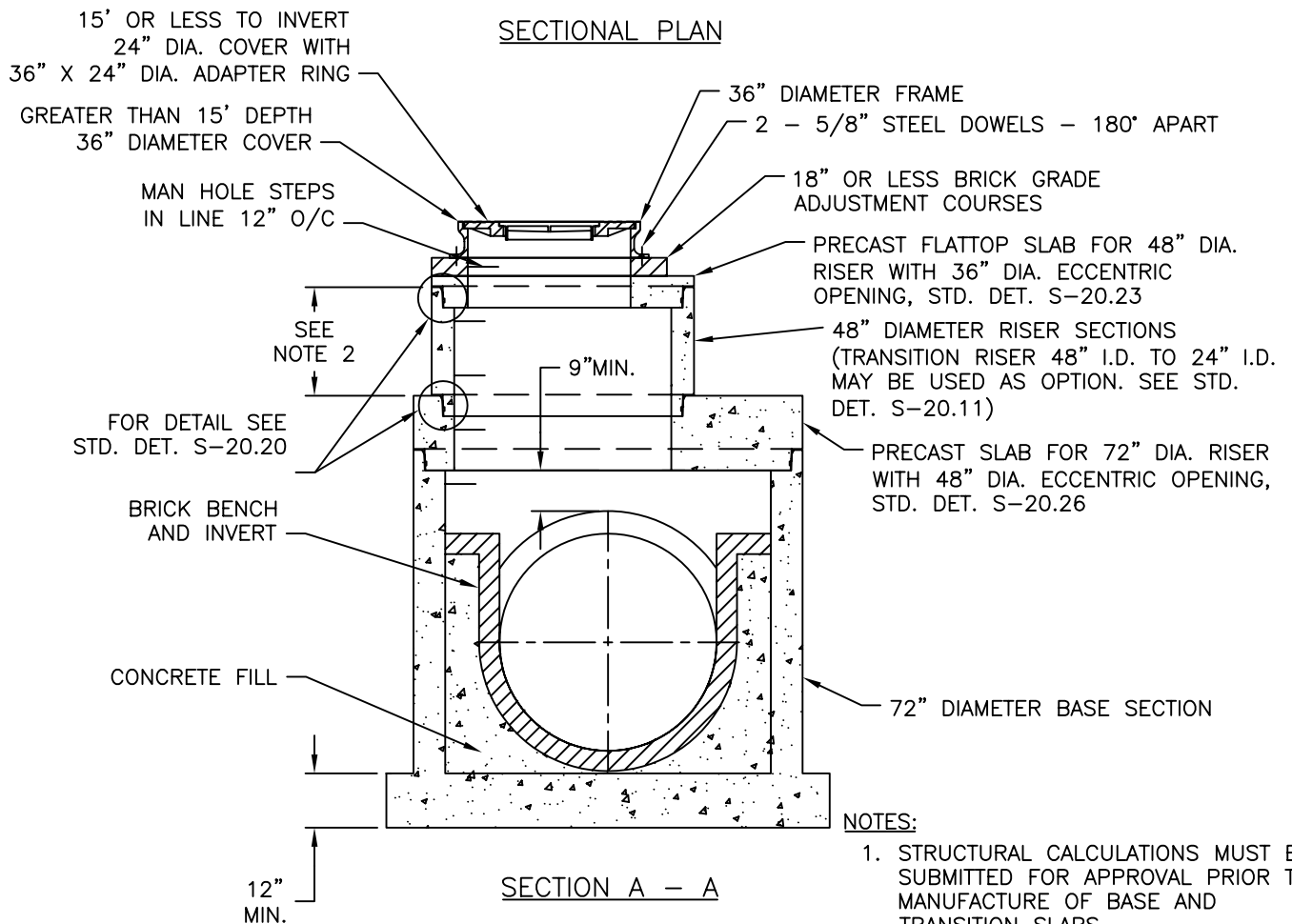

NOTES:

1. STRUCTURAL CALCULATIONS MUST BE SUBMITTED FOR APPROVAL PRIOR TO MANUFACTURE OF BASE AND TRANSITION SLABS.
2. 1', 2', 3' OR 4' OR A COMBINATION THEREOF AS NEEDED FOR GRADE ADJUSTMENT

APPROVED DATE: June 20, 2003

DIRECTOR, DEPARTMENT OF ENGINEERING
AND TECHNICAL SERVICES

REVISION NO.: 0
DATE: 6/20/03
PREPARED BY: OBG/BKJV
CHECKED BY: W.DARROW

STANDARD DETAIL
PRECAST CONCRETE MANHOLE
FOR NEW 33" THRU 48" DIAMETER SEWERS
(72" DIAMETER PRECAST BASE)

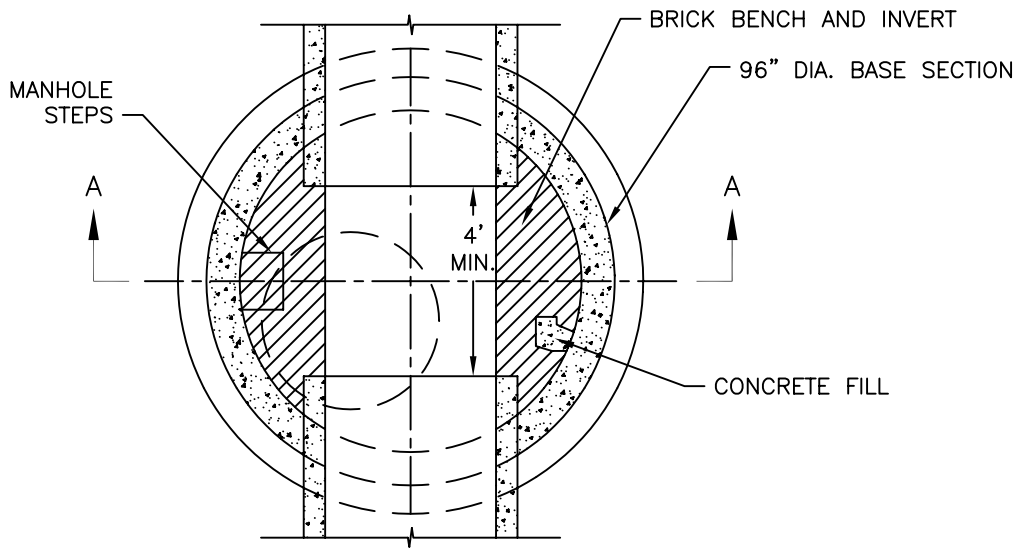

SECTIONAL PLAN

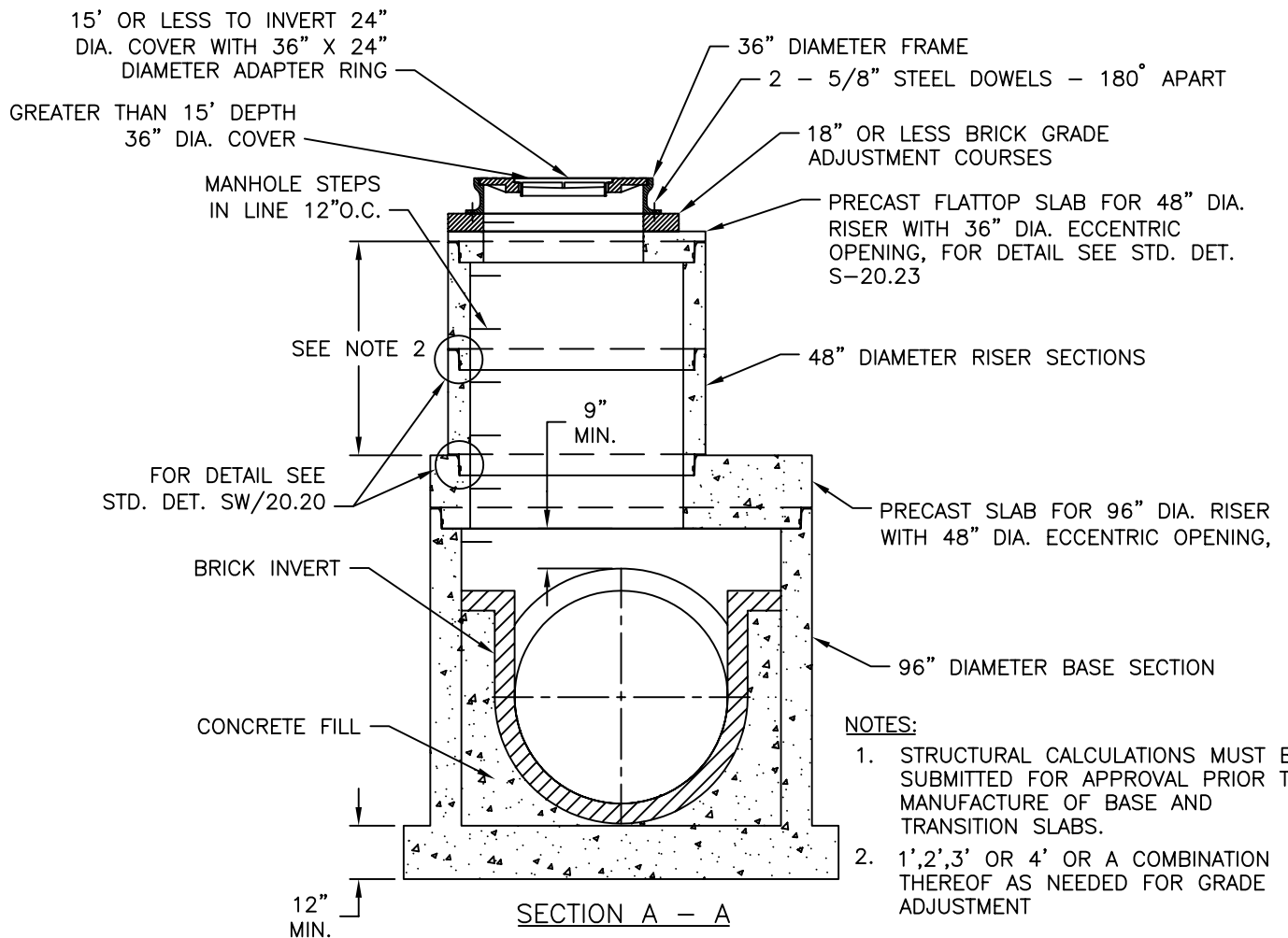

NOTES:

1. STRUCTURAL CALCULATIONS MUST BE SUBMITTED FOR APPROVAL PRIOR TO MANUFACTURE OF BASE AND TRANSITION SLABS.
2. 1', 2', 3' OR 4' OR A COMBINATION THEREOF AS NEEDED FOR GRADE ADJUSTMENT

APPROVED DATE: June 20, 2003

DIRECTOR, DEPARTMENT OF ENGINEERING AND TECHNICAL SERVICES

REVISION NO.: 0
DATE: 6/20/03
PREPARED BY: OBG/BKJV
CHECKED BY: W.DARROW

STANDARD DETAIL
PRECAST CONCRETE MANHOLE
FOR NEW 54" THRU 60" DIAMETER SEWERS
(96" DIAMETER PRECAST BASE)

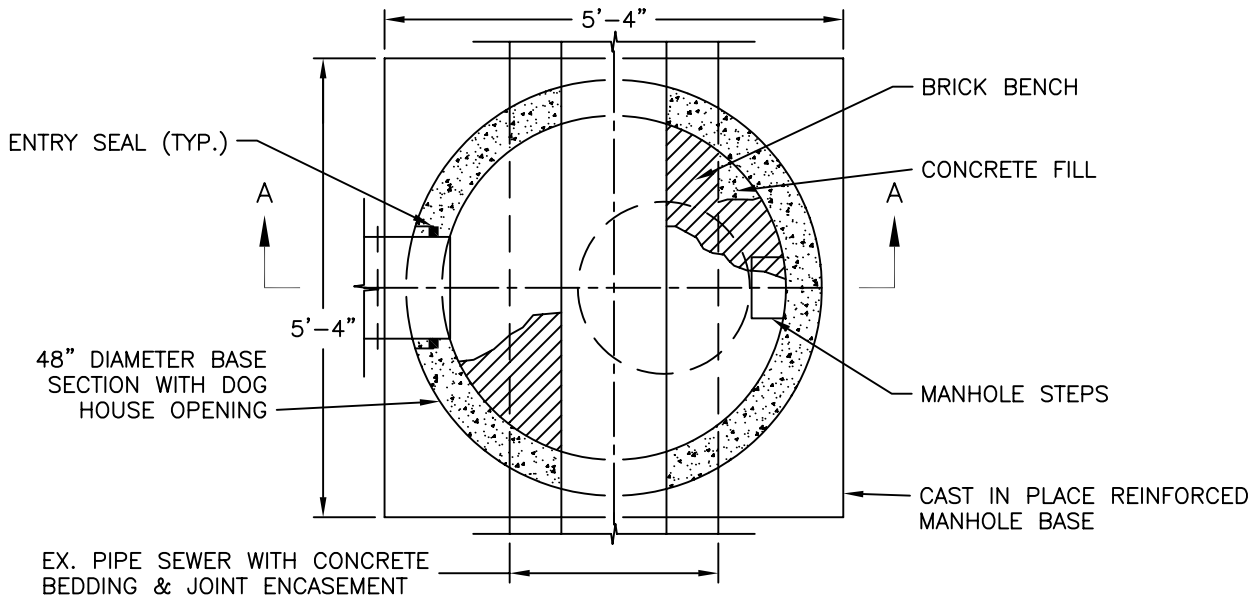

SECTIONAL PLAN

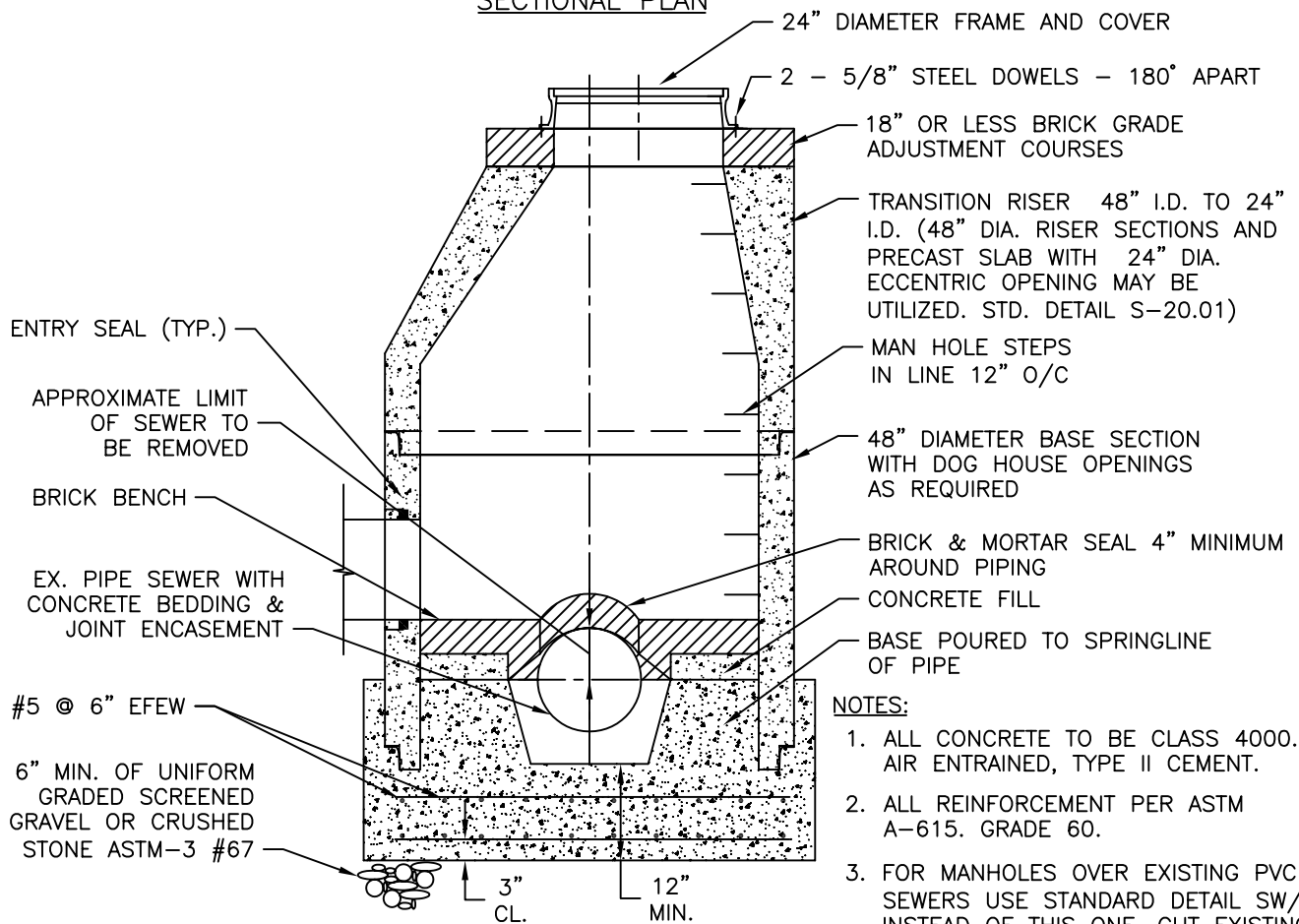

SECTION A - A

NOTES:

1. ALL CONCRETE TO BE CLASS 4000. AIR ENTRAINED, TYPE II CEMENT.
2. ALL REINFORCEMENT PER ASTM A-615. GRADE 60.
3. FOR MANHOLES OVER EXISTING PVC SEWERS USE STANDARD DETAIL SW/20.01 INSTEAD OF THIS ONE. CUT EXISTING PVC SEWER AND RECONNECT ON EITHER SIDE OF MANHOLE

APPROVED DATE: June 20, 2003

DIRECTOR, DEPARTMENT OF ENGINEERING
AND TECHNICAL SERVICES

REVISION NO.: 0
DATE: 6/20/03
PREPARED BY: OBG/BKJV
CHECKED BY: W.DARROW

STANDARD DETAIL
PRECAST CONCRETE MANHOLE OVER EXISTING
10" THRU 21" DIAMETER SEWERS WITH
CAST IN PLACE CONCRETE BASE

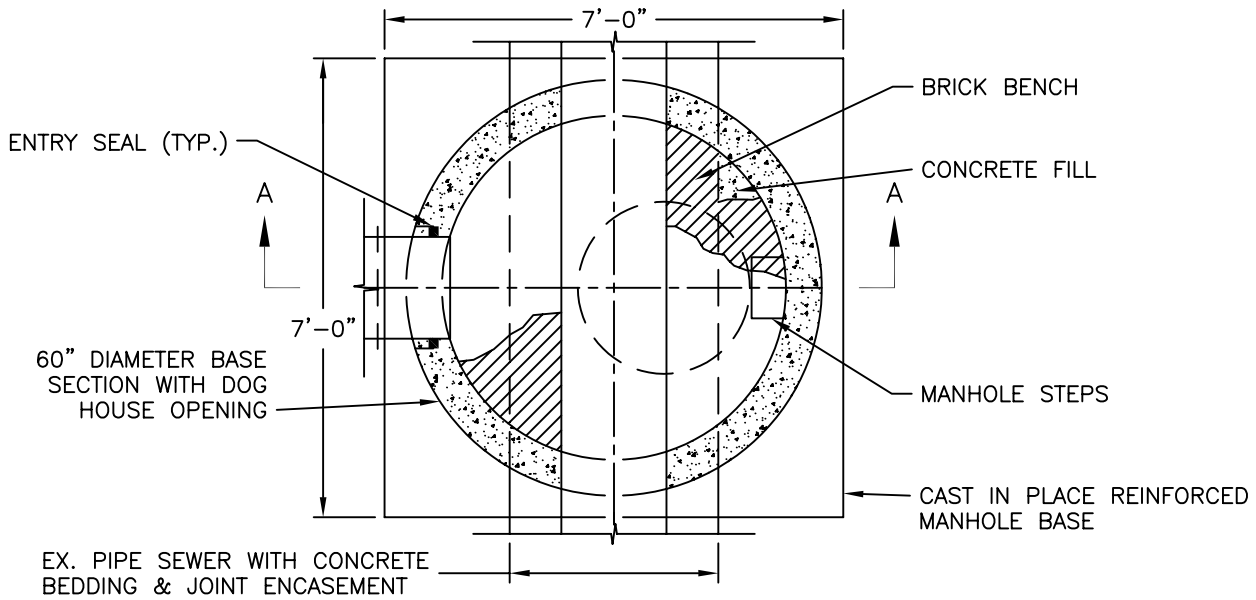

SECTIONAL PLAN

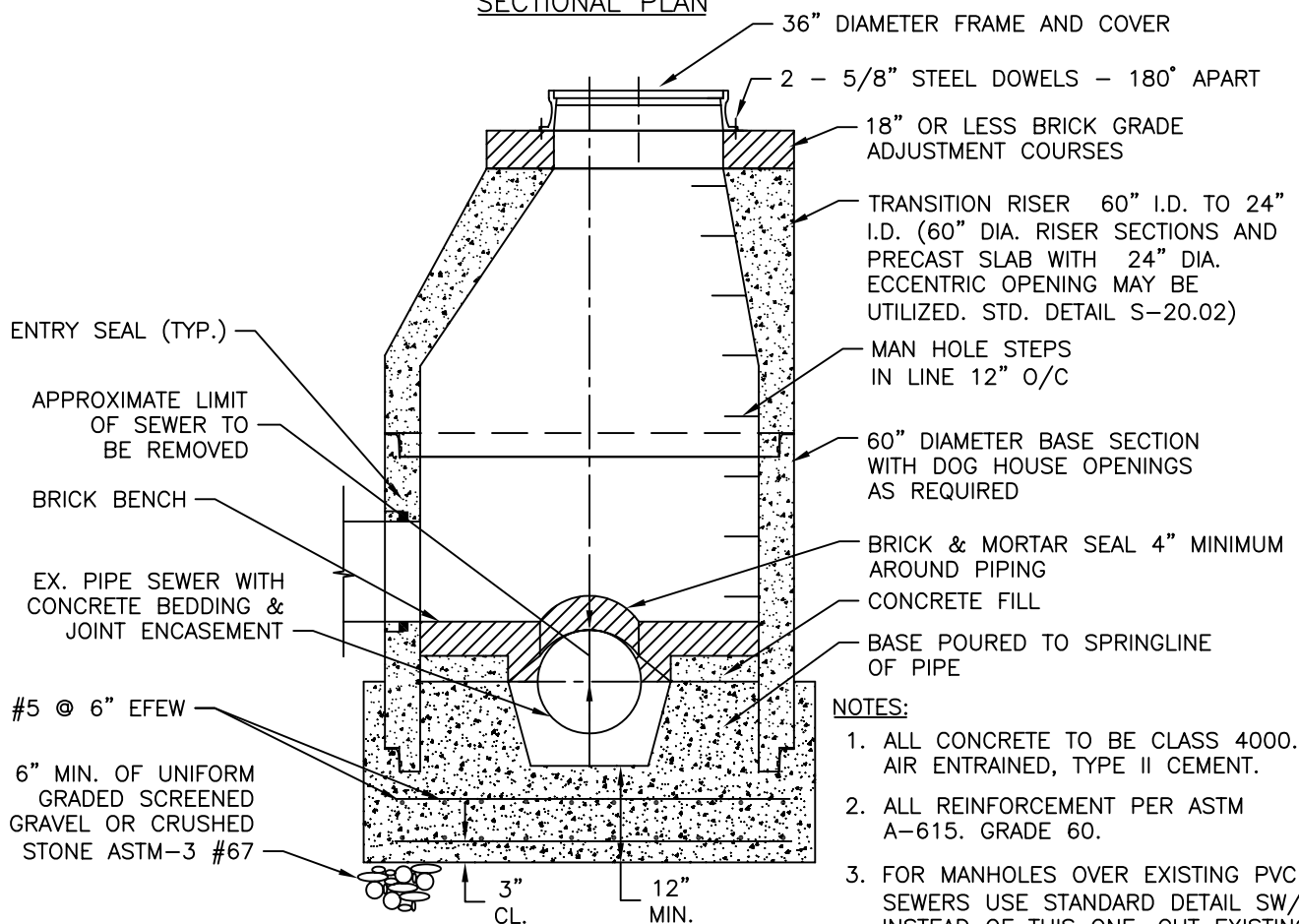

SECTION A - A

NOTES:

1. ALL CONCRETE TO BE CLASS 4000. AIR ENTRAINED, TYPE II CEMENT.
2. ALL REINFORCEMENT PER ASTM A-615. GRADE 60.
3. FOR MANHOLES OVER EXISTING PVC SEWERS USE STANDARD DETAIL SW/20.02 INSTEAD OF THIS ONE. CUT EXISTING PVC SEWER AND RECONNECT ON EITHER SIDE OF MANHOLE

APPROVED DATE: June 20, 2003

DIRECTOR, DEPARTMENT OF ENGINEERING AND TECHNICAL SERVICES

REVISION NO.: 0
DATE: 6/20/03
PREPARED BY: OBG/BKJV
CHECKED BY: W.DARROW

STANDARD DETAIL
PRECAST CONCRETE MANHOLE OVER EXISTING
24" THRU 30" DIAMETER SEWERS WITH
CAST IN PLACE CONCRETE BASE

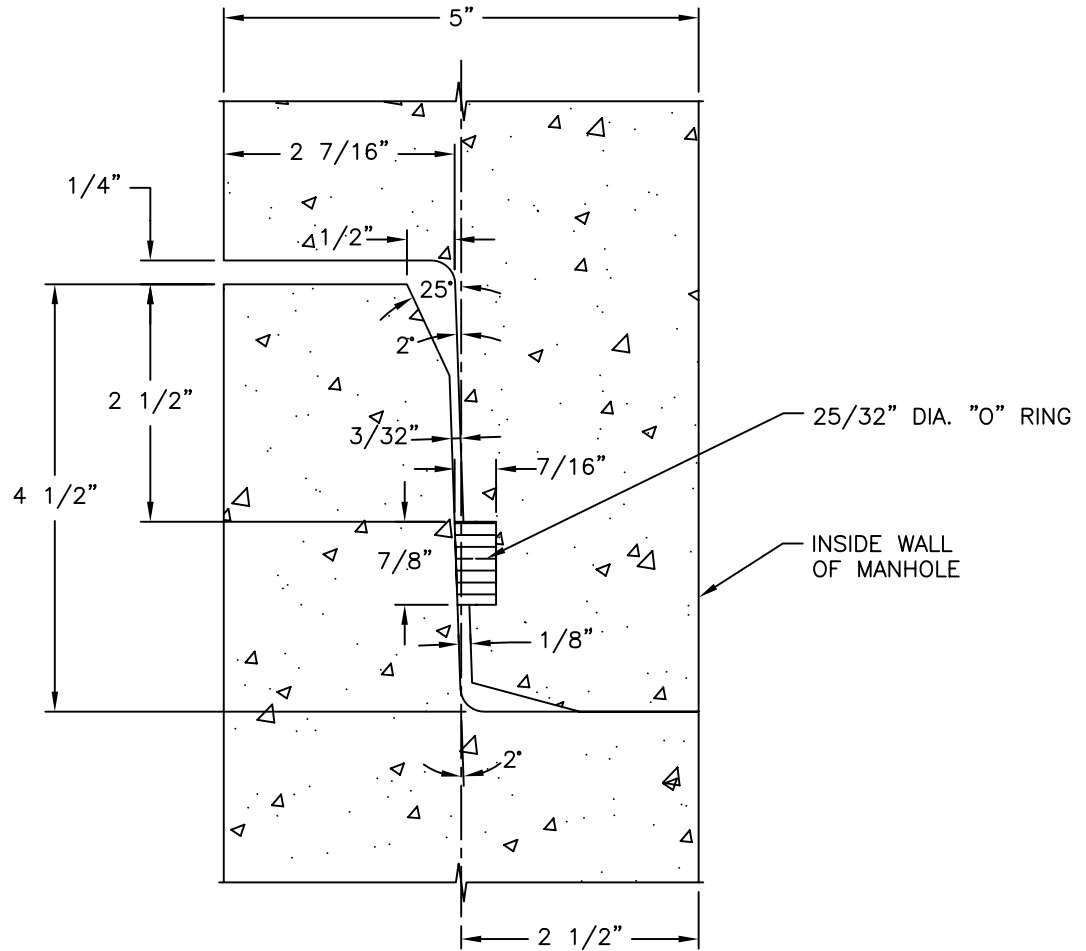

JOINT DETAIL

NOTE:
FOR CLARITY, REINFORCING NOT SHOWN.

APPROVED DATE: June 20, 2003

DIRECTOR, DEPARTMENT OF ENGINEERING
AND TECHNICAL SERVICES

REVISION NO.: 0
DATE: 6/20/03
PREPARED BY: OBG/BKJV
CHECKED BY: W.DARROW

STANDARD DETAIL

PIPE RISER JOINT DETAIL
(48" DIAMETER RISER)

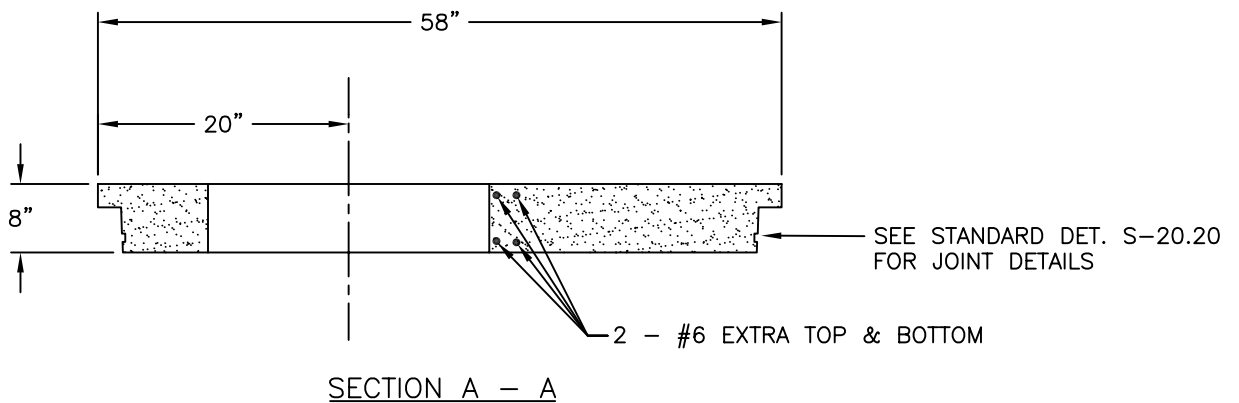
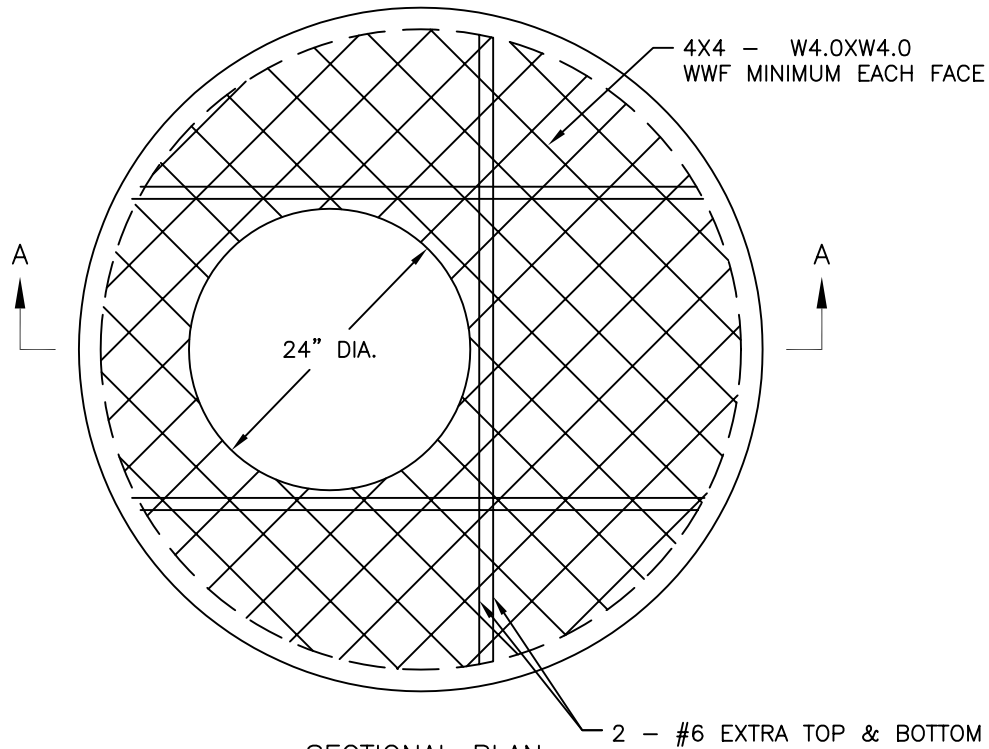

NOTES:

1. ALL CONCRETE TO BE CLASS 4000, AIR ENTRAINED, TYPE II CEMENT
2. REINFORCING STEEL SHALL CONFORM TO ASTM A615, GRADE 60
3. WWF PER ASTM A185

APPROVED DATE: June 20, 2003

DIRECTOR, DEPARTMENT OF ENGINEERING
 AND TECHNICAL SERVICES

REVISION NO.: 0
 DATE: 6/20/03
 PREPARED BY: OBG/BKJV
 CHECKED BY: W.DARROW

STANDARD DETAIL
 PRECAST FLATTOP SLAB
 FOR 48" DIAMETER MANHOLE RISER
 WITH 24" DIAMETER ECCENTRIC OPENING

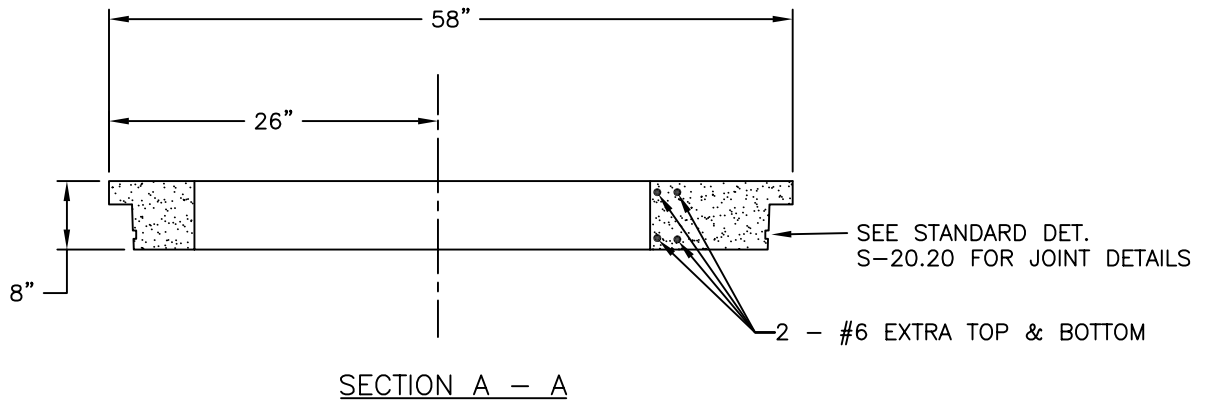
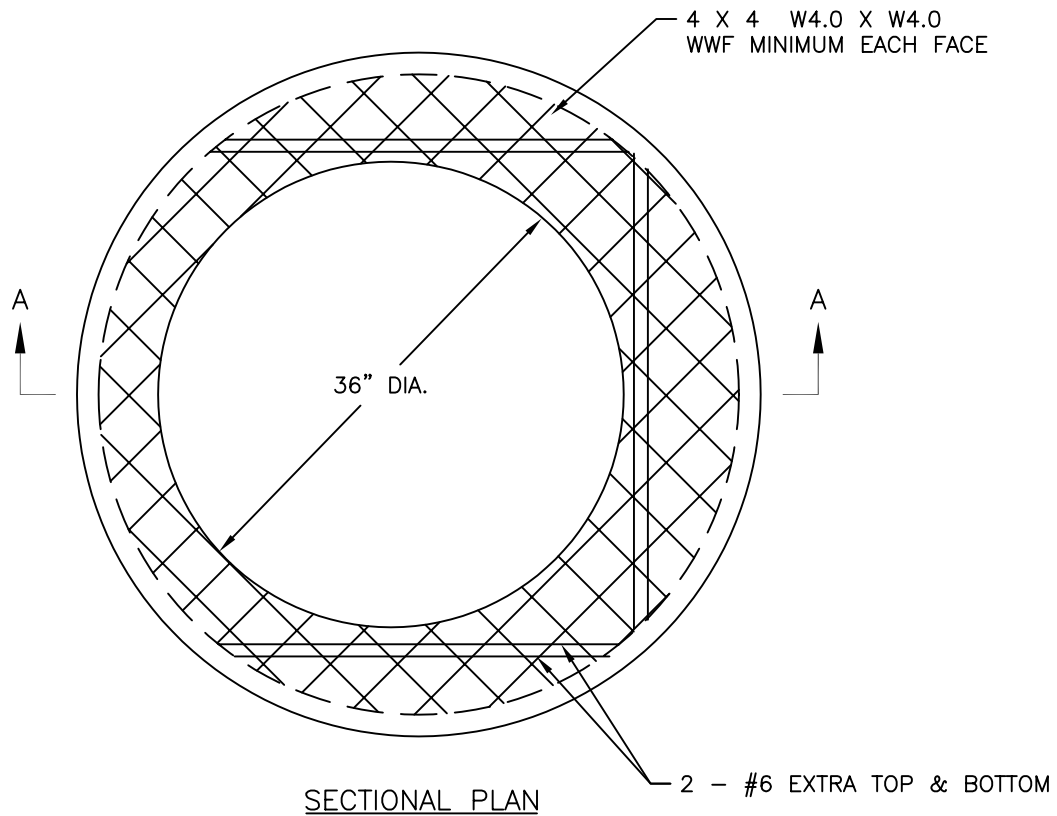

NOTES:

1. ALL CONCRETE TO BE CLASS 4000, AIR ENTRAINED, TYPE II CEMENT
2. REINFORCING STEEL SHALL CONFORM TO ASTM A615, GRADE 60
3. WWF PER ASTM A185

APPROVED DATE: June 20, 2003

DIRECTOR, DEPARTMENT OF ENGINEERING
AND TECHNICAL SERVICES

REVISION NO.: 0
DATE: 6/20/03
PREPARED BY: OBG/BKJV
CHECKED BY: W.DARROW

STANDARD DETAIL
PRECAST FLATTOP SLAB
FOR 48" DIAMETER MANHOLE RISER
WITH 36" DIAMETER ECCENTRIC OPENING

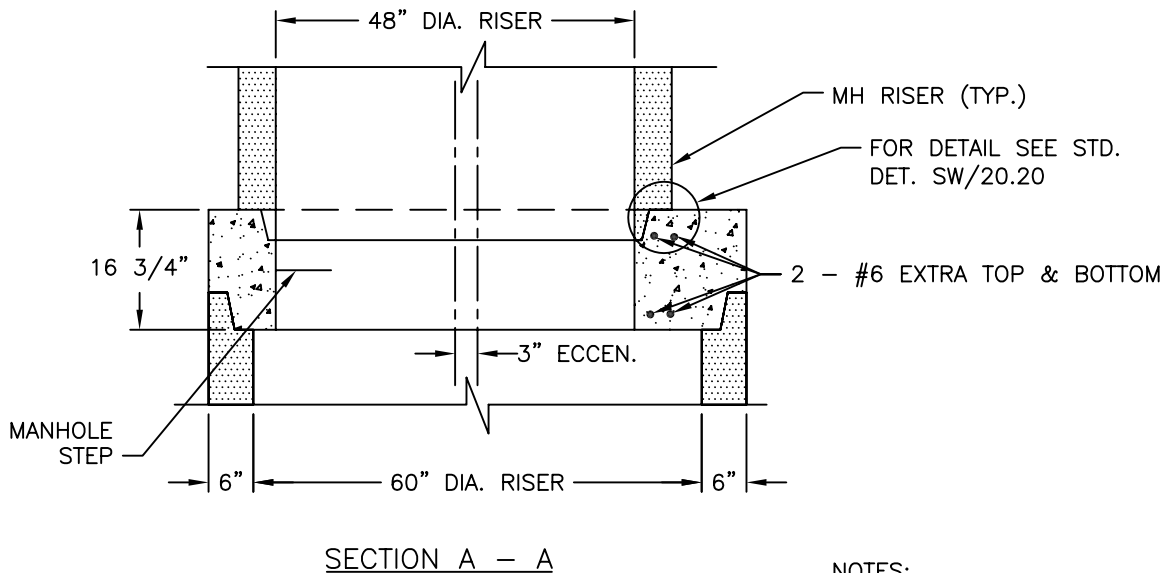
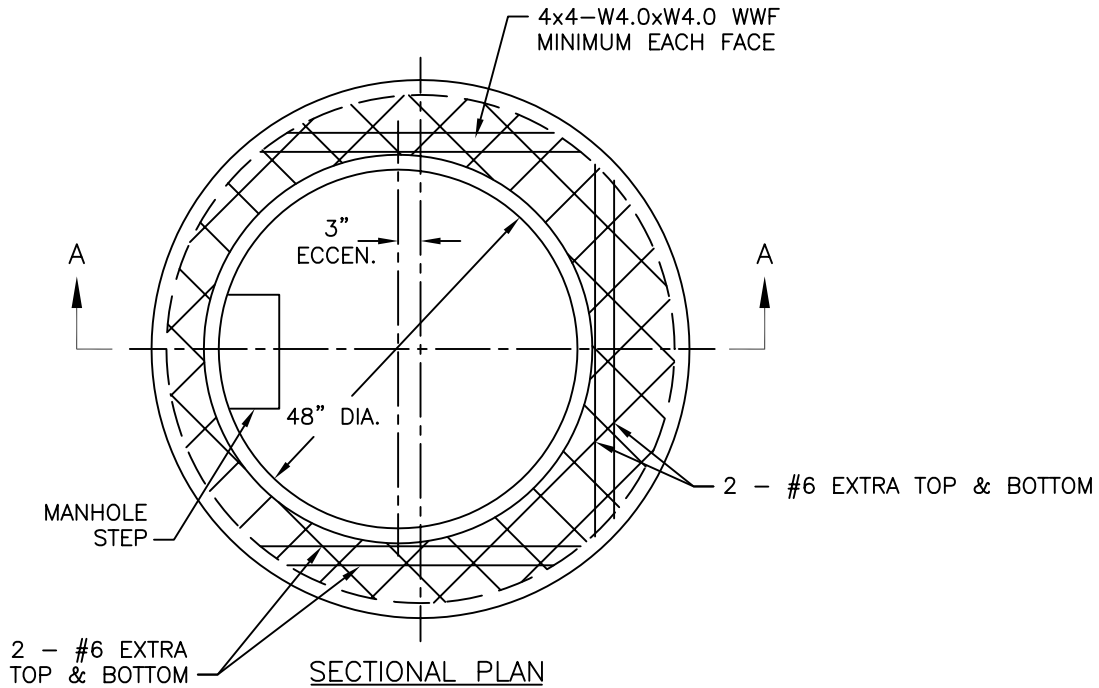

NOTES:

1. STRUCTURAL CALCULATIONS MUST BE SUBMITTED FOR APPROVAL PRIOR TO MANUFACTURE.
2. ALL CONCRETE TO BE CLASS 4000, AIR ENTRAINED, TYPE II CEMENT.
3. REINFORCING STEEL SHALL CONFORM TO ASTM A615, GRADE 60.
4. WWF PER ASTM A185

APPROVED DATE: June 20, 2003

DIRECTOR, DEPARTMENT OF ENGINEERING
AND TECHNICAL SERVICES

REVISION NO.: 0
DATE: 6/20/03
PREPARED BY: OBG/BKJV
CHECKED BY: W.DARROW

STANDARD DETAIL
PRECAST REDUCER SLAB
FOR 60" DIAMETER MANHOLE RISER
TO 48" DIAMETER ECCENTRIC RISER

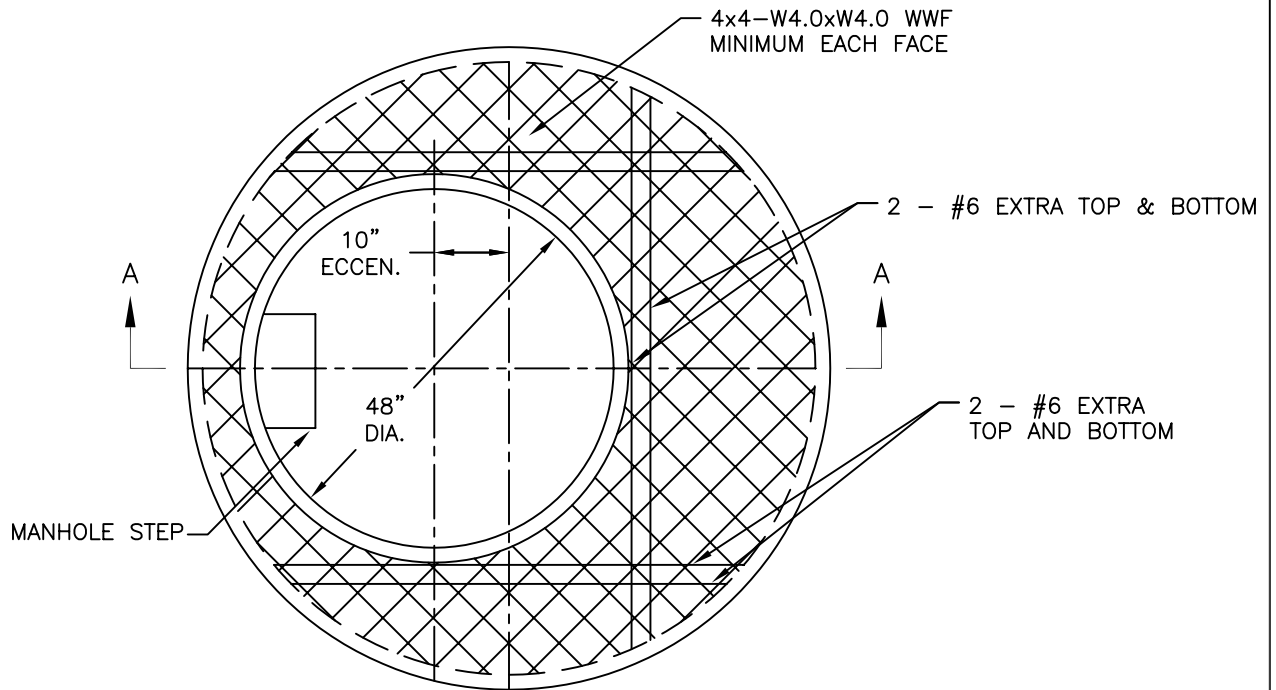

SECTIONAL PLAN

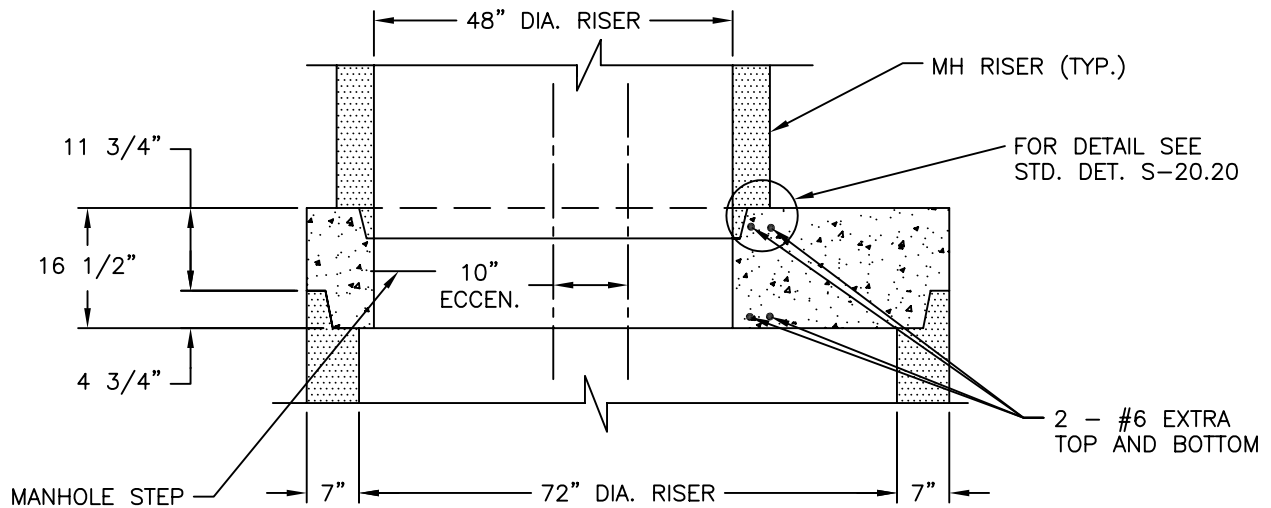

SECTION A - A

NOTES:

1. STRUCTURAL CALCULATIONS MUST BE SUBMITTED FOR APPROVAL PRIOR TO MANUFACTURE
2. ALL CONCRETE TO BE CLASS 4000, AIR ENTRAINED, TYPE II CEMENT
3. REINFORCING STEEL SHALL CONFORM TO ASTM A615, GRADE 60
4. WWF PER ASTM A185

APPROVED DATE: June 20, 2003

DIRECTOR, DEPARTMENT OF ENGINEERING
AND TECHNICAL SERVICES

REVISION NO.: 0
DATE: 6/20/03
PREPARED BY: OBG/BKJV
CHECKED BY: W.DARROW

STANDARD DETAIL
PRECAST REDUCER SLAB
FOR 72" DIAMETER MANHOLE RISER
TO 48" DIAMETER ECCENTRIC RISER

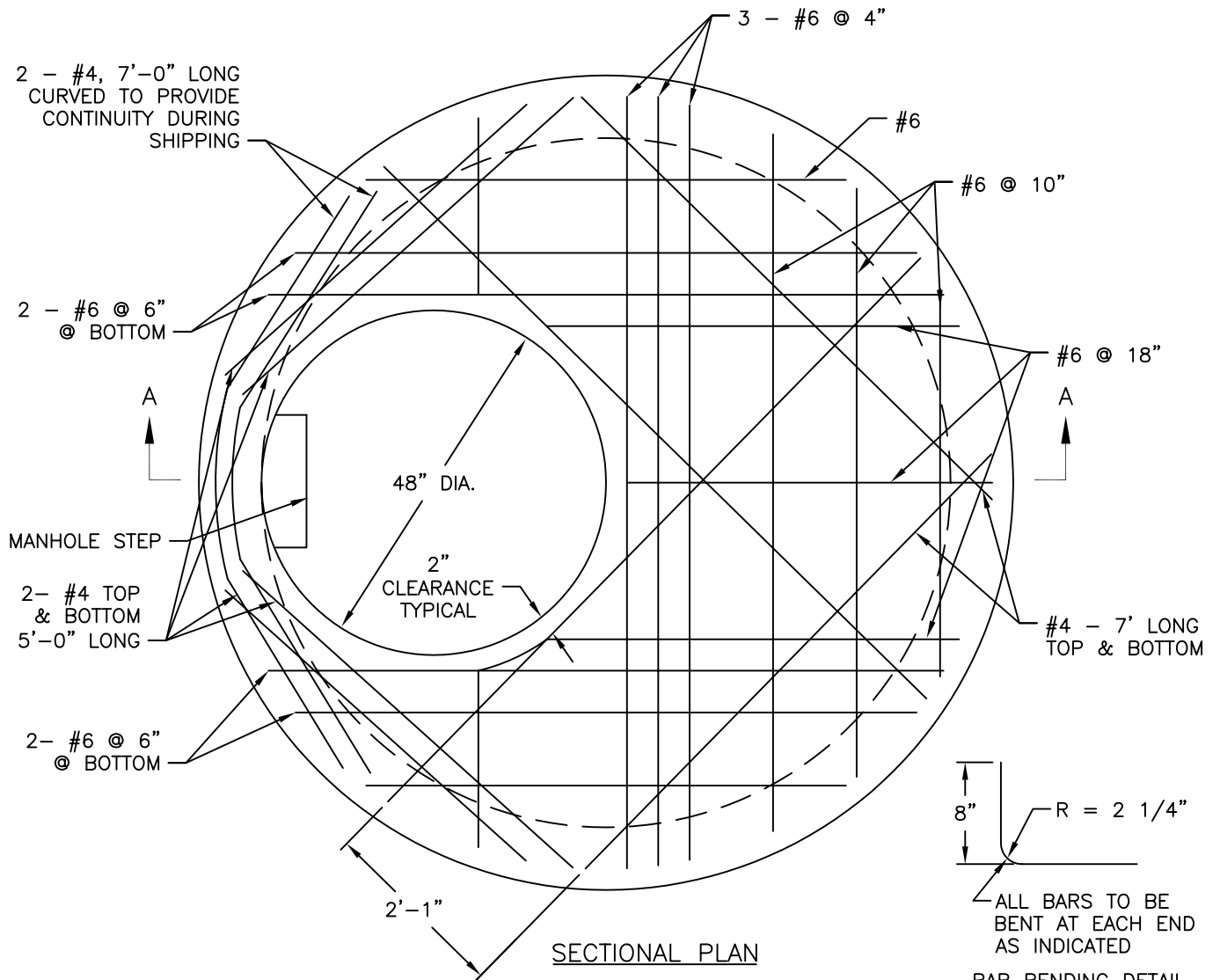

PROVIDE AT LEAST (3) #4
CIRCUMFERENTIAL REBARS
AS INDICATED

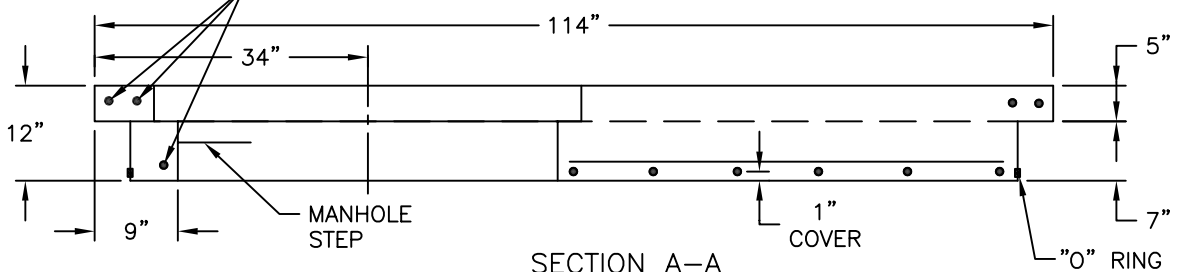

NOTES:

1. STRUCTURAL CALCULATIONS MUST BE SUBMITTED FOR APPROVAL PRIOR TO MANUFACTURE.

APPROVED DATE: June 20, 2003

DIRECTOR, DEPARTMENT OF ENGINEERING
AND TECHNICAL SERVICES

REVISION NO.: 0
DATE: 6/20/03
PREPARED BY: OBG/BKJV
CHECKED BY: W.DARROW

STANDARD DETAIL
PRECAST REDUCER SLAB
FOR 96" DIAMETER MANHOLE RISER
TO 48" DIAMETER ECCENTRIC RISER

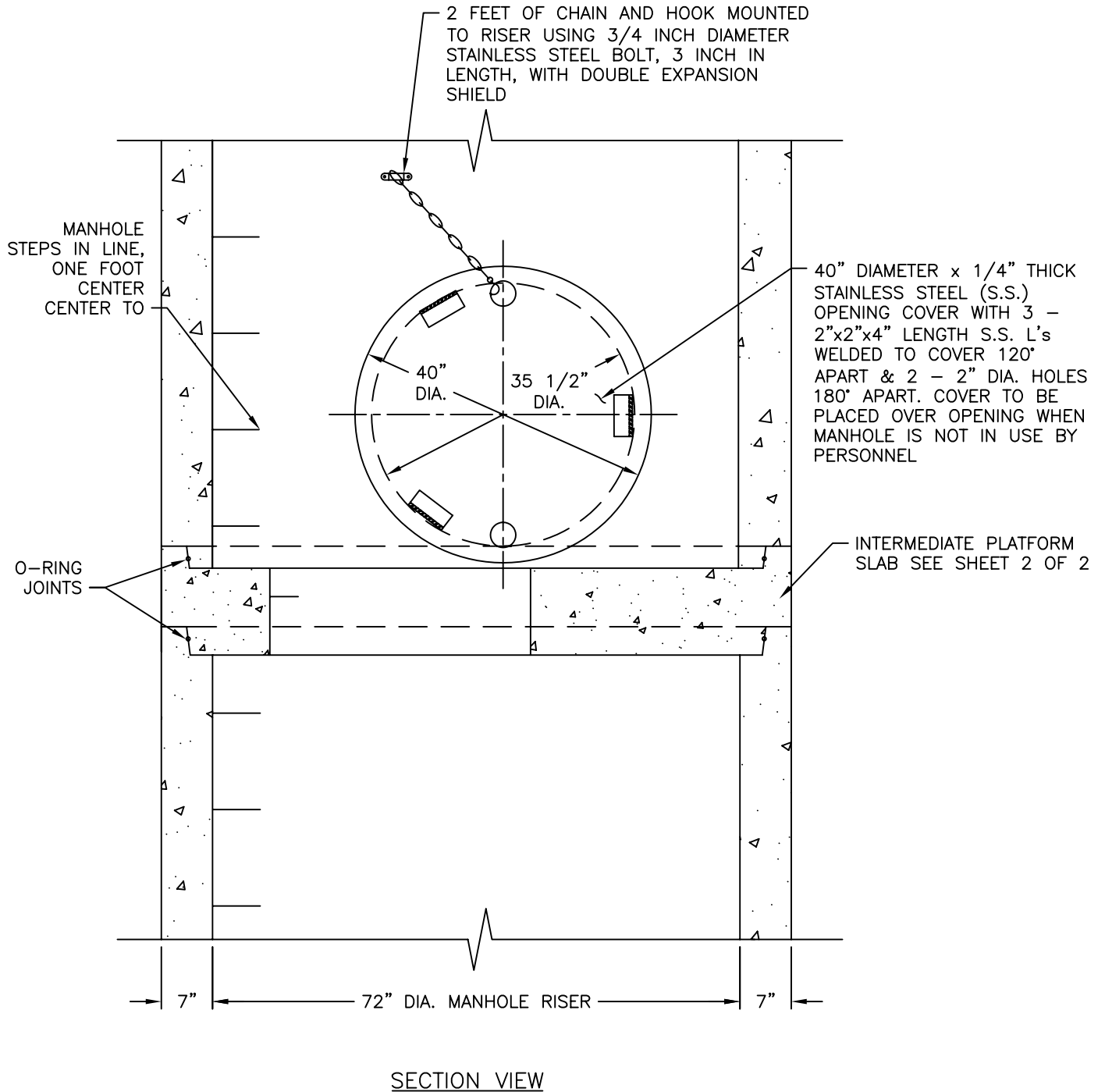

APPROVED DATE: June 20, 2003

DIRECTOR, DEPARTMENT OF ENGINEERING AND TECHNICAL SERVICES

REVISION NO.: 0
DATE: 6/20/03
PREPARED BY: OBG/BKJV
CHECKED BY: W.DARROW

STANDARD DETAIL
INTERMEDIATE PLATFORM SLAB
FOR 72" DIAMETER MANHOLE RISER WITH
36" DIAMETER ACCESS OPENING AND COVER

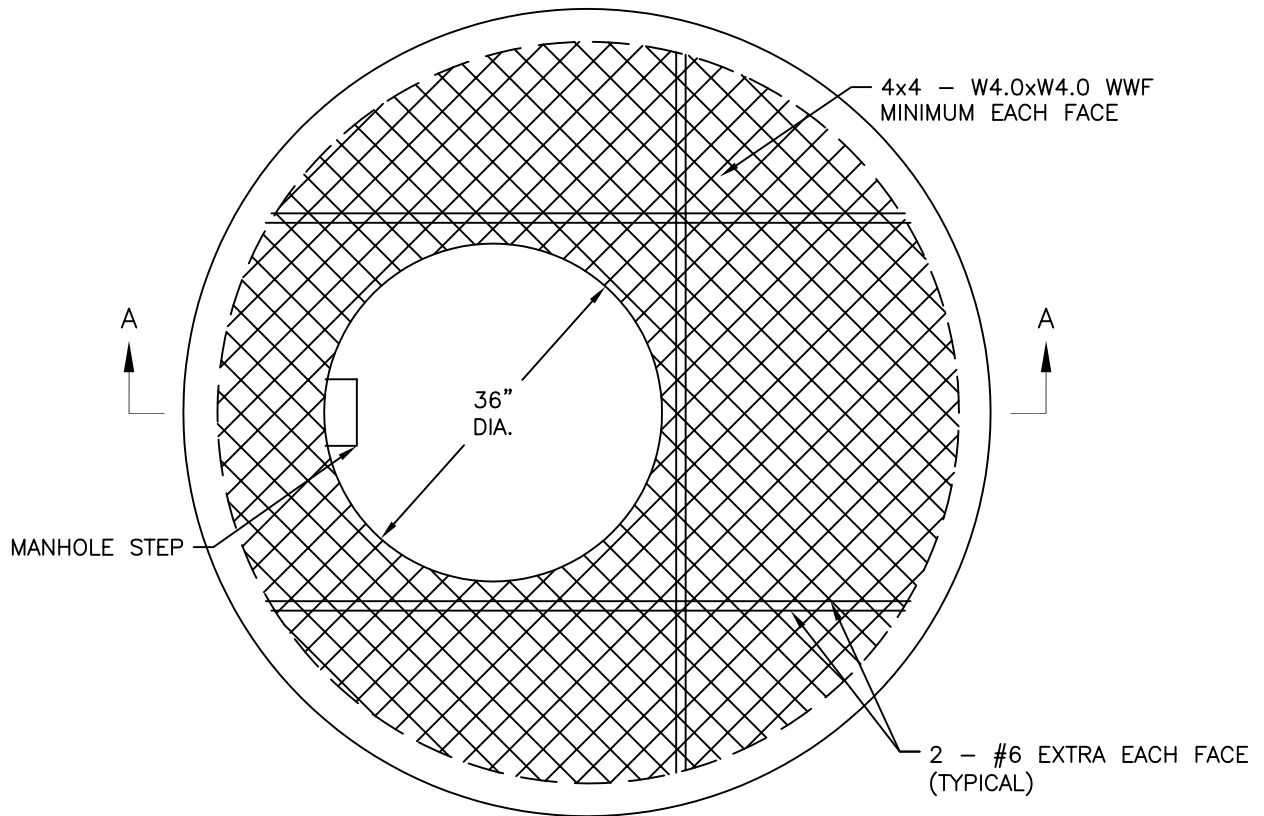

SECTIONAL PLAN

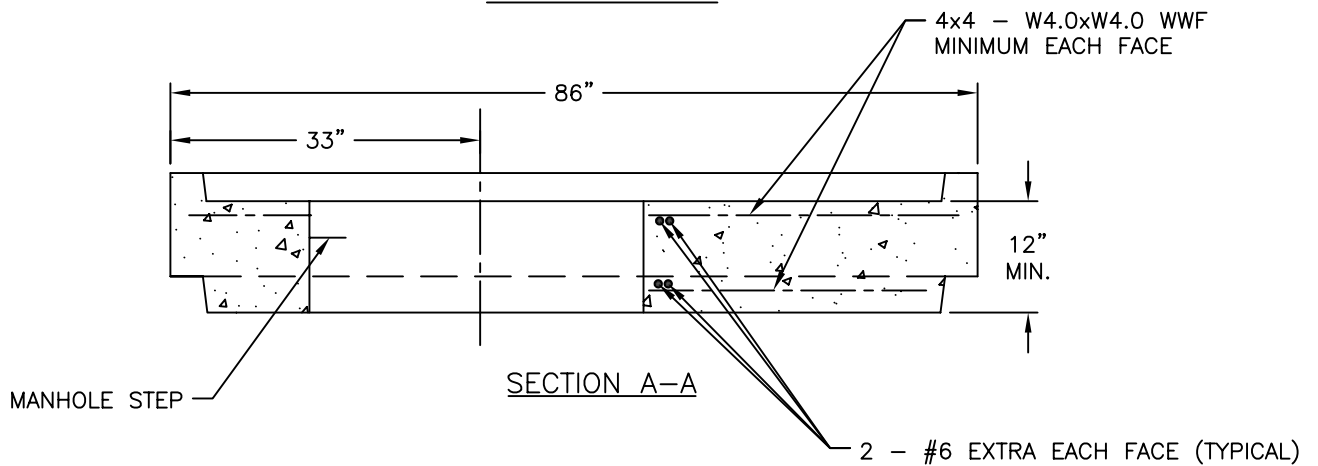

SECTION A-A

NOTES:

1. STRUCTURAL CALCULATIONS MUST BE SUBMITTED FOR APPROVAL PRIOR TO MANUFACTURE
2. ALL CONCRETE TO BE CLASS 4000, AIR ENTRAINED, TYPE II CEMENT.
3. ALL REINFORCING SHALL HAVE A MINIMUM OF 2-INCHES OF COVER.
4. REINFORCING STEEL SHALL CONFORM TO ASTM A615, GRADE 60
5. WWF PER ASTM A185

APPROVED DATE: June 20, 2003

DIRECTOR, DEPARTMENT OF ENGINEERING
 AND TECHNICAL SERVICES

REVISION NO.: 0
 DATE: 6/20/03
 PREPARED BY: OBG/BKJV
 CHECKED BY: W.DARROW

STANDARD DETAIL
 INTERMEDIATE PLATFORM SLAB
 FOR 72" DIAMETER MANHOLE RISER WITH
 36" DIAMETER ACCESS OPENING AND COVER

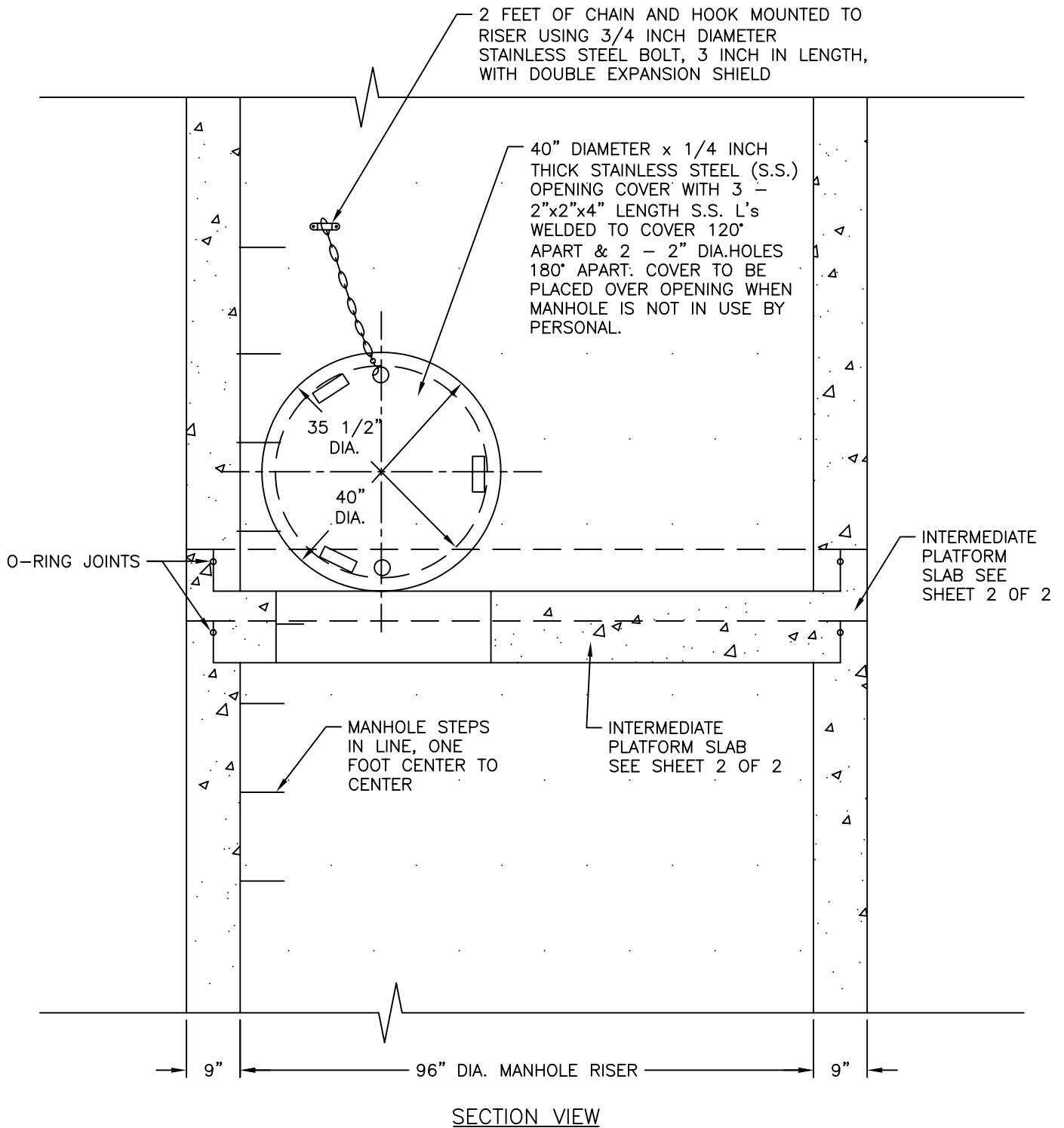

APPROVED DATE: June 20, 2003

DIRECTOR, DEPARTMENT OF ENGINEERING AND TECHNICAL SERVICES

REVISION NO.: 0
DATE: 6/20/03
PREPARED BY: OBG/BKJV
CHECKED BY: W.DARROW

STANDARD DETAIL
INTERMEDIATE PLATFORM SLAB
FOR 96" DIAMETER MANHOLE RISER
WITH 36" DIA. ACCESS OPENING AND COVER

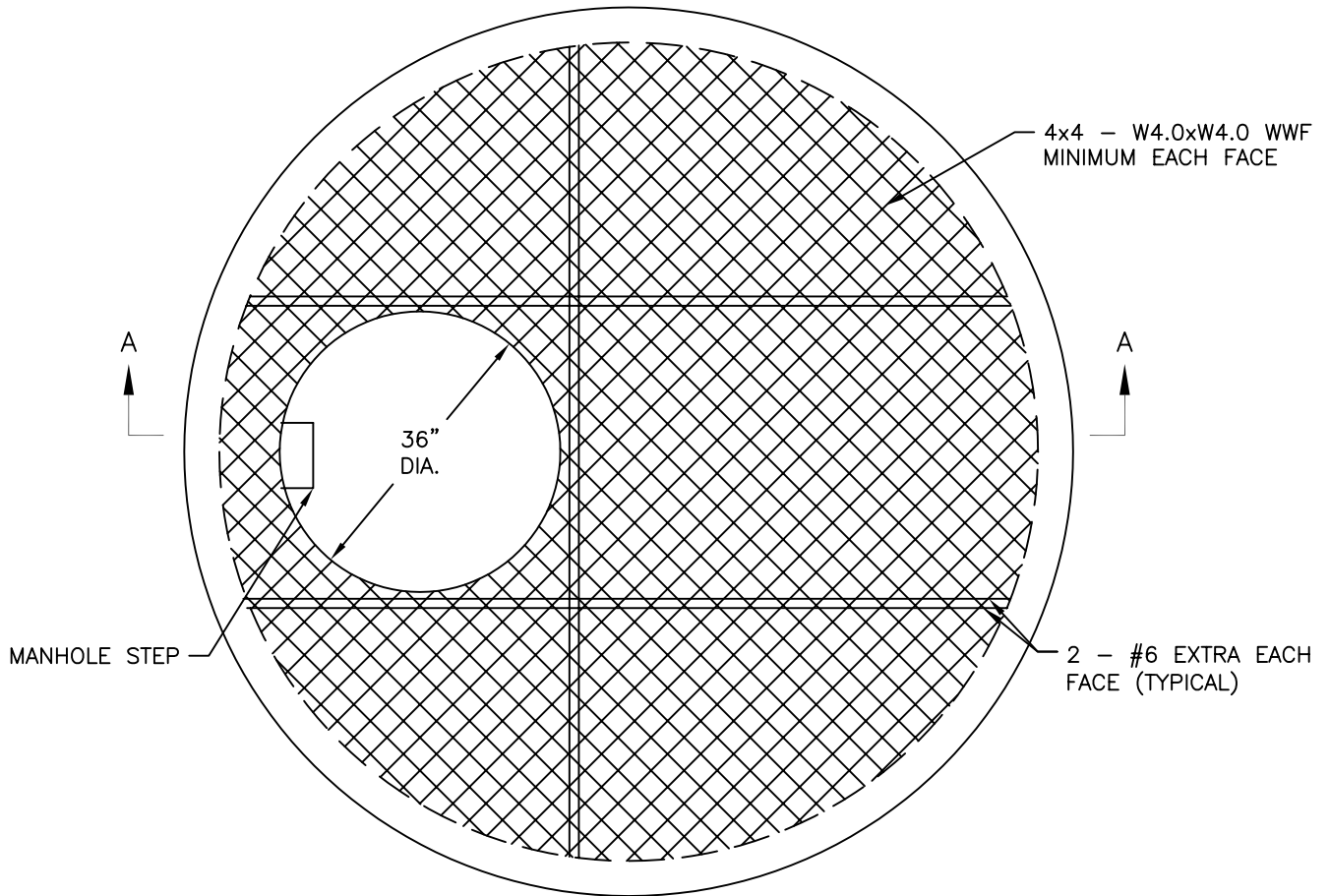

SECTIONAL PLAN

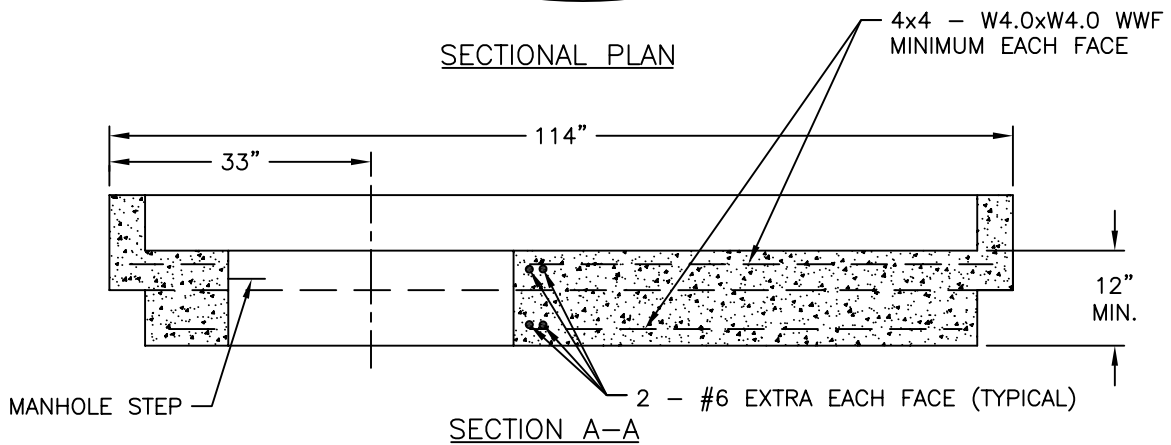

NOTES:

1. STRUCTURAL CALCULATIONS MUST BE SUBMITTED FOR APPROVAL PRIOR TO MANUFACTURE OF INTERMEDIATE PLATFORM SLAB.
2. ALL CONCRETE TO BE CLASS 4000, AIR ENTRAINED, TYPE II CEMENT.
3. ALL REINFORCING SHALL HAVE A MINIMUM OF 2-INCHES OF COVER.
4. REINFORCING STEEL SHALL CONFORM TO ASTM A615, GRADE 60.
5. WWF PER ASTM A185.

APPROVED DATE: June 20, 2003

DIRECTOR, DEPARTMENT OF ENGINEERING
AND TECHNICAL SERVICES

REVISION NO.: 0
DATE: 6/20/03
PREPARED BY: OBG/BKJV
CHECKED BY: W.DARROW

STANDARD DETAIL
INTERMEDIATE PLATFORM SLAB
FOR 96" DIAMETER MANHOLE RISER
WITH 36" DIA. ACCESS OPENING AND COVER

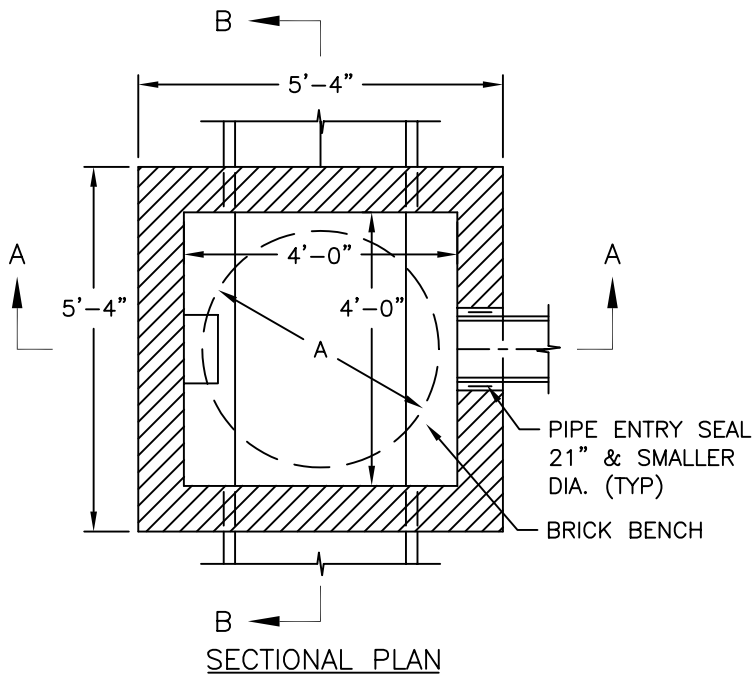

SEWER DIAMETER	FRAME DIAMETER (A)
10" THRU 21"	24"
24" THRU 36"	36" *

* IF SURFACE TO INVERT < 15', A 36"X24" DIA. ADAPTER RING WITH 24" DIA. COVER SHALL BE USED.

NOTES:

1. ALL CONCRETE TO BE CLASS 4000, AIR ENTRAINED, TYPE II CEMENT
2. REINFORCING STEEL SHALL CONFORM TO ASTM A-615, GRADE 60
3. WHEN THE MANHOLE DEPTH EXCEEDS 15 FEET, THE BRICK WALL THICKNESS SHALL BE INCREASED TO 12 INCHES BELOW THE 15 FOOT DEPTH

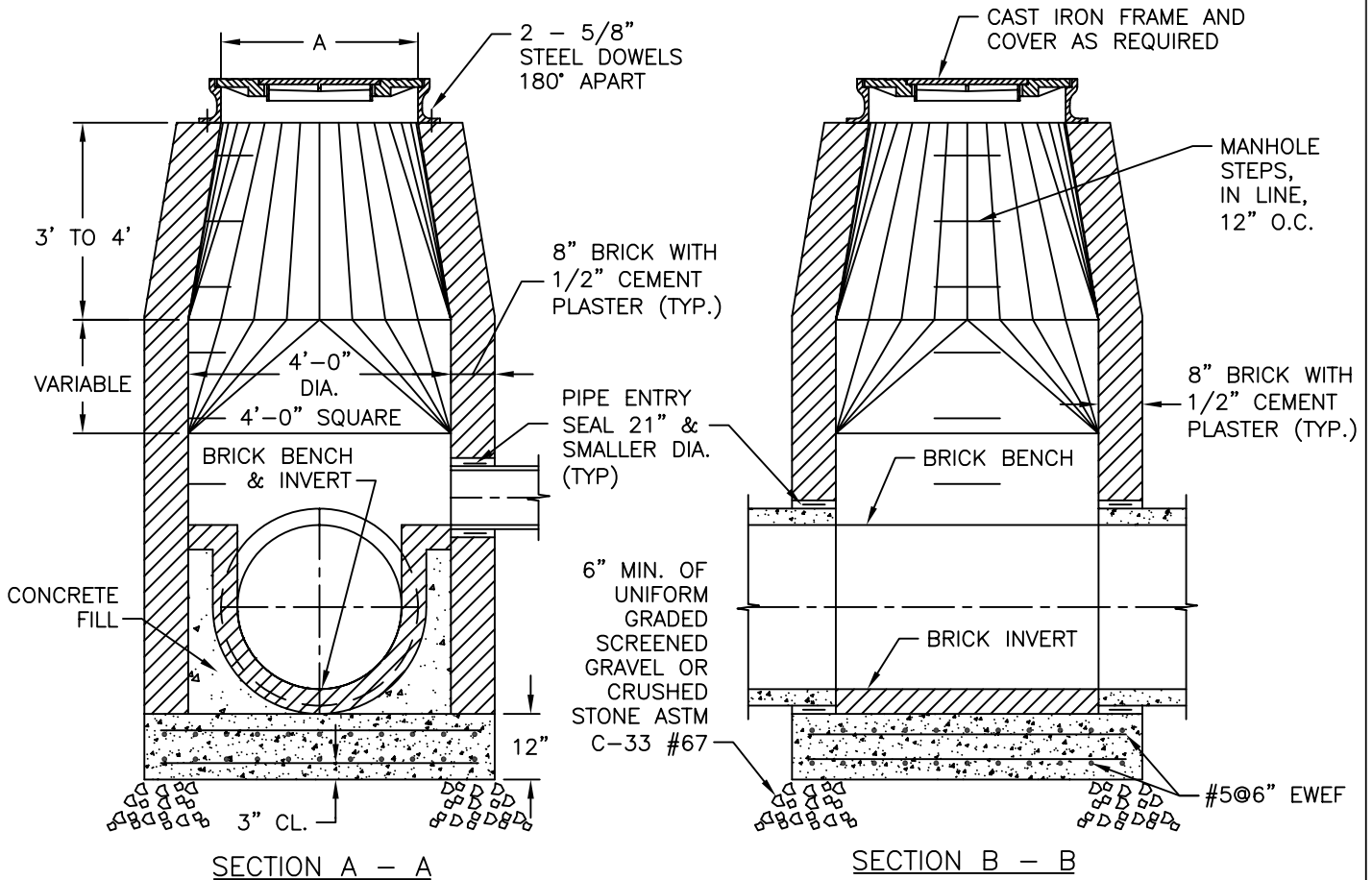

APPROVED DATE: June 20, 2003

DIRECTOR, DEPARTMENT OF ENGINEERING
AND TECHNICAL SERVICES

REVISION NO.: 0
DATE: 6/20/03
PREPARED BY: OBG/BKJV
CHECKED BY: W.DARROW

STANDARD DETAIL
BRICK MANHOLE
FOR NEW 10" THRU 36" DIAMETER SEWERS
WITH CAST IN PLACE CONCRETE BASE

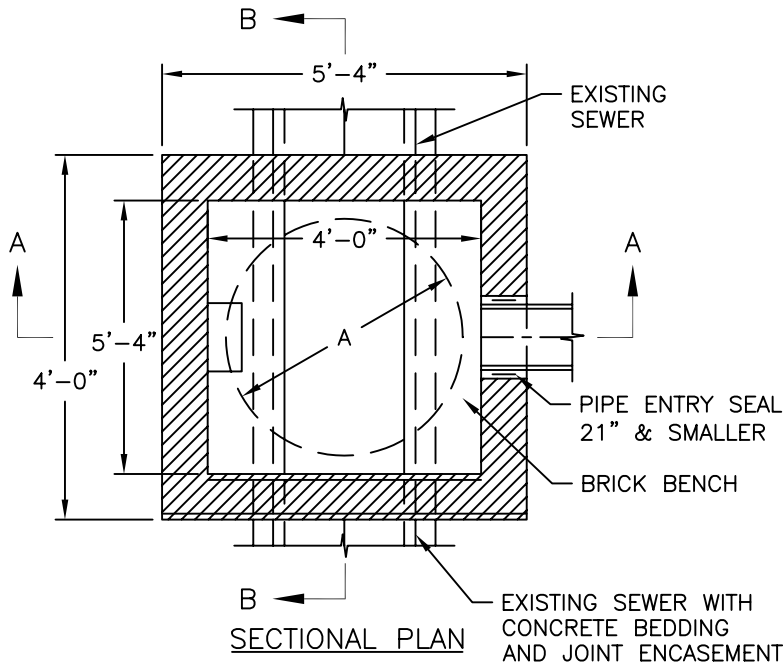

SEWER DIAMETER	FRAME DIAMETER (A)
10" THRU 21"	24"
24" THRU 36"	36" *

* IF SURFACE TO INVERT < 15', A 36"X24" DIA. ADAPTER RING WITH 24" DIA. COVER SHALL BE USED.

NOTES:

1. ALL CONCRETE TO BE CLASS 4000 AIR ENTRAINED, TYPE II CEMENT.
2. REINFORCING STEEL SHALL CONFORM TO ASTM A-615, GRADE 60.
3. WHEN THE MANHOLE DEPTH EXCEEDS 15 FEET, THE BRICK WALL THICKNESS SHALL BE INCREASED TO 12 INCHES BELOW THE 15 FOOT DEPTH.

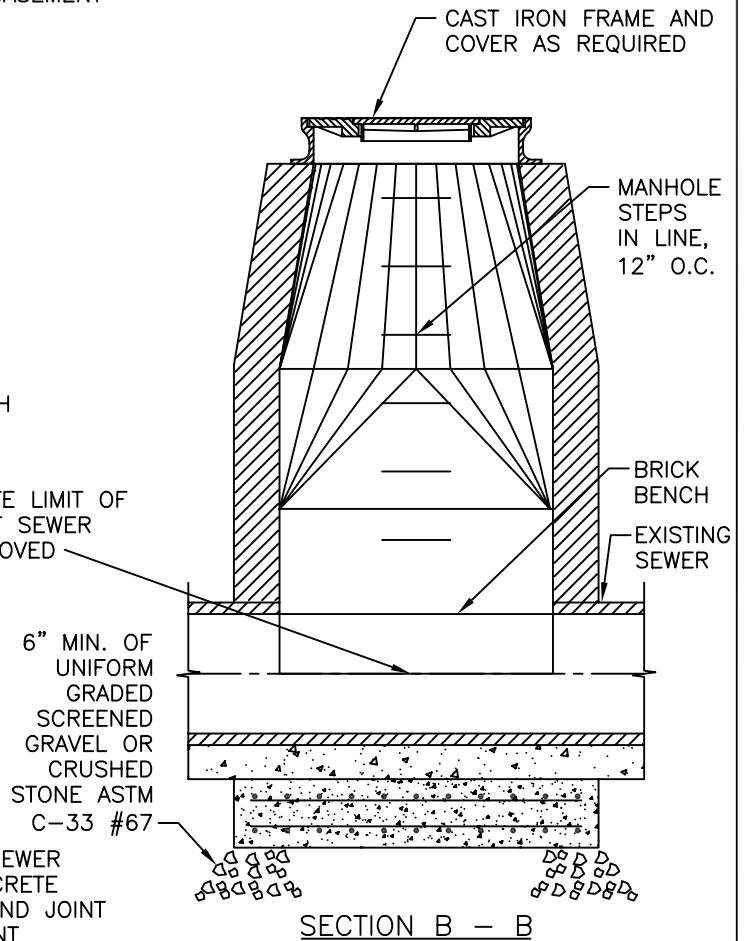
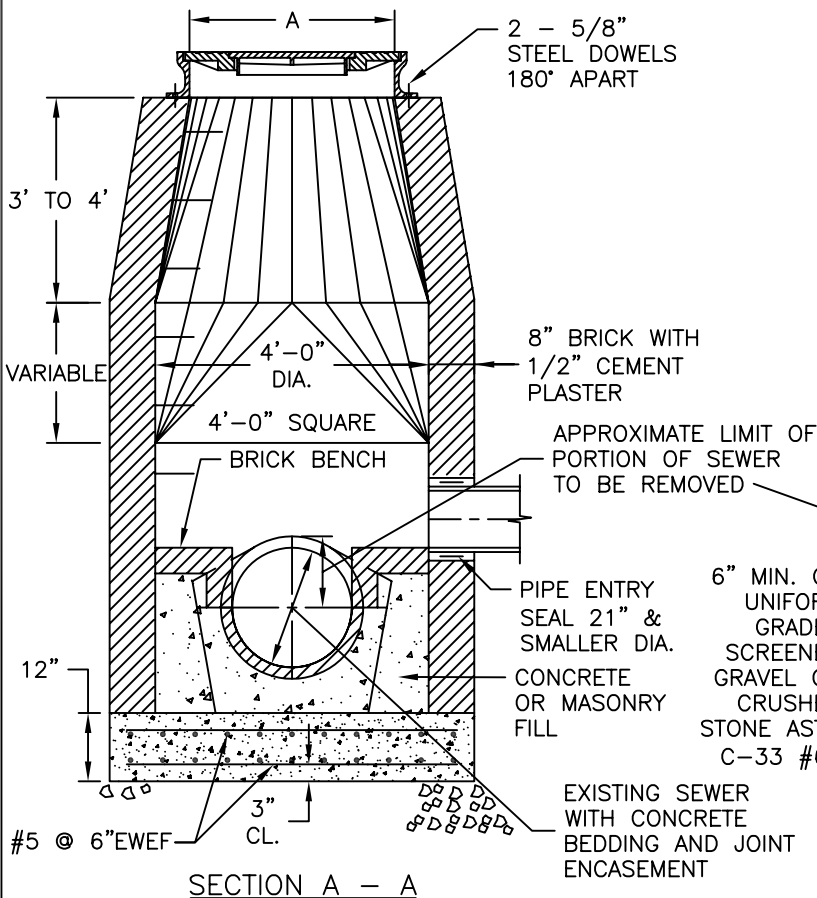

APPROVED DATE: June 20, 2003

DIRECTOR, DEPARTMENT OF ENGINEERING
AND TECHNICAL SERVICES

REVISION NO.: 0
DATE: 6/20/03
PREPARED BY: OBG/BKJV
CHECKED BY: W.DARROW

STANDARD DETAIL
BRICK MANHOLE
OVER EXISTING 10" THRU 36" DIAMETER
SEWERS WITH CAST IN PLACE CONCRETE BASE

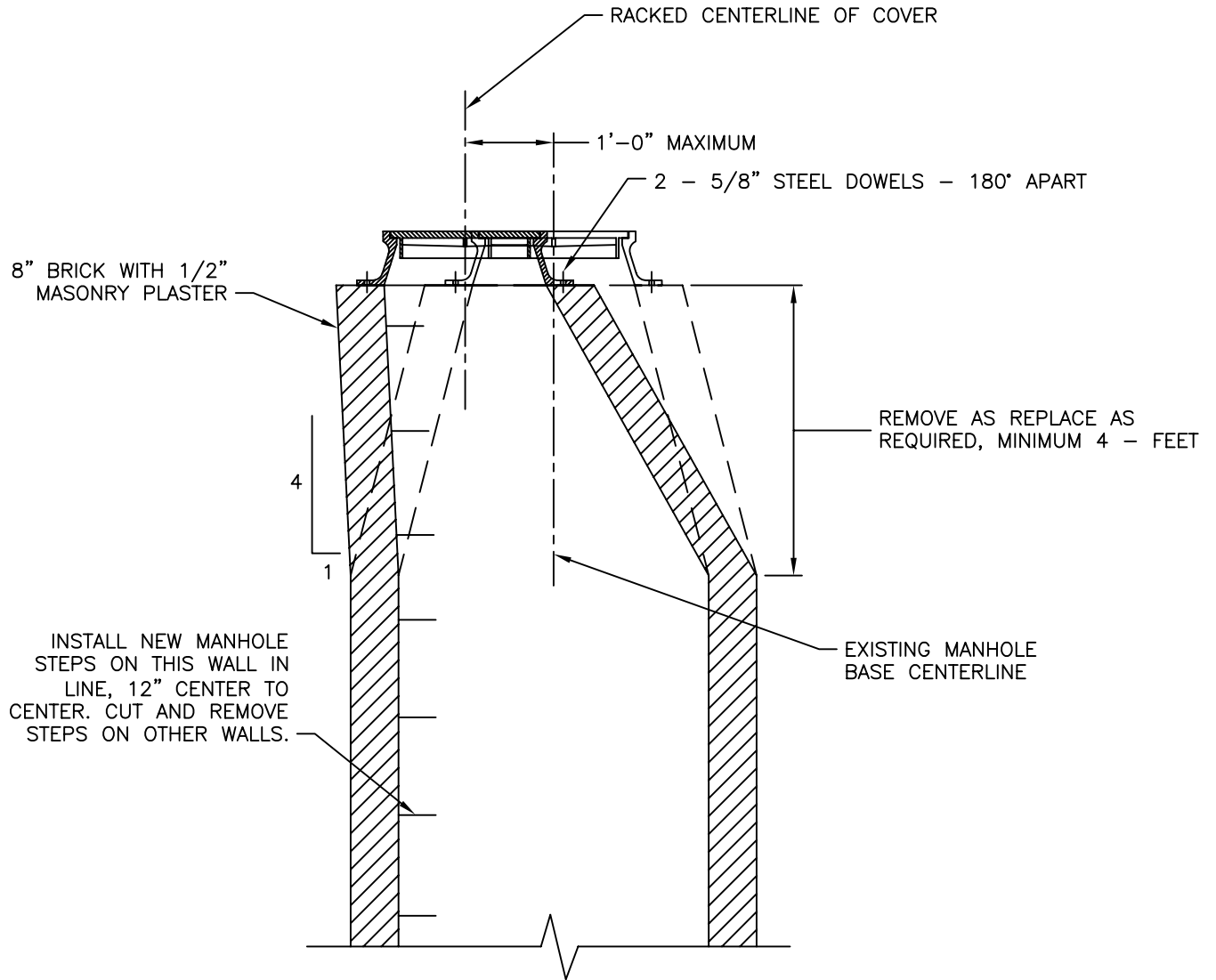

SECTIONAL VIEW

SEWER DIAMETER	FRAME AND COVER DIAMETER (A)
10" THRU 21"	24"
24" THRU 36"	36" *

* 15 - FEET OR LESS, SURFACE TO INVERT, A 36" X 24" DIAMETER ADAPTER RING WITH 24" DIAMETER COVER SHALL BE USED.

APPROVED DATE: June 20, 2003

DIRECTOR, DEPARTMENT OF ENGINEERING
AND TECHNICAL SERVICES

REVISION NO.: 0
DATE: 6/20/03
PREPARED BY: OBG/BKJV
CHECKED BY: W.DARROW

STANDARD DETAIL
BRICK MANHOLE RACKING

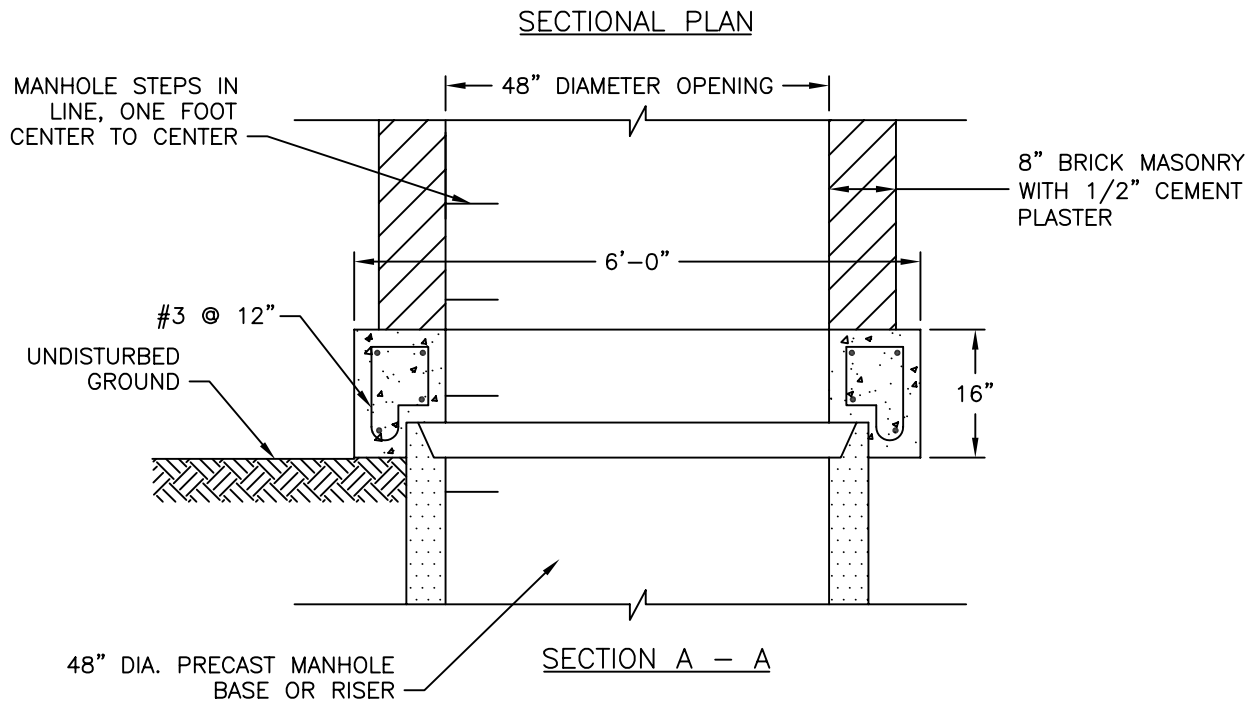
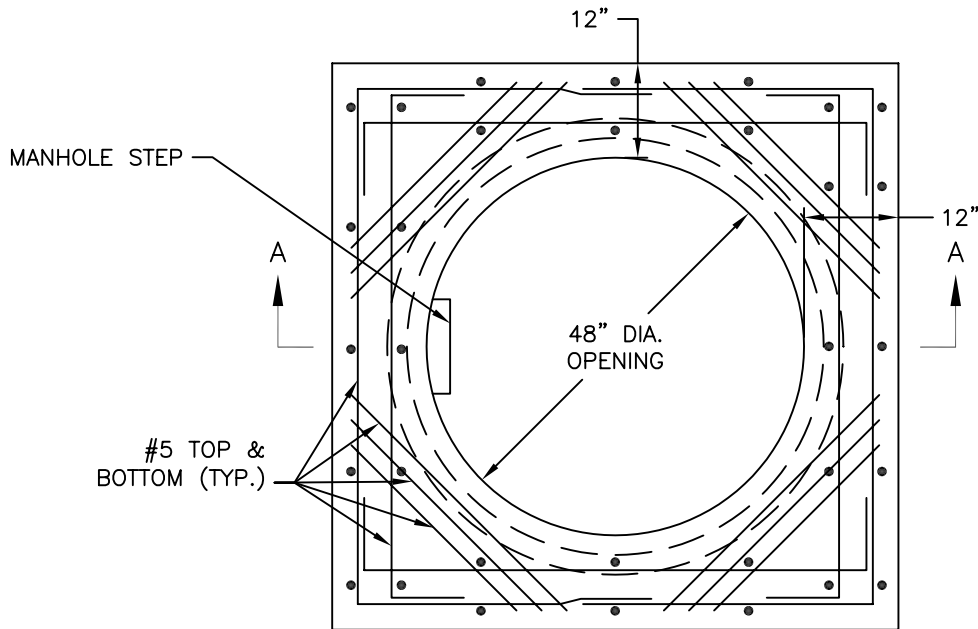

NOTES:

1. ALL CONCRETE TO BE CLASS 4000, AIR ENTRAINED, TYPE II CEMENT.
2. REINFORCING STEEL SHALL CONFIRM TO ASTM A-615 GRADE 60.

APPROVED DATE: June 20, 2003

DIRECTOR, DEPARTMENT OF ENGINEERING
AND TECHNICAL SERVICES

REVISION NO.: 0
DATE: 6/20/03
PREPARED BY: OBG/BKJV
CHECKED BY: W.DARROW

STANDARD DETAIL
CONCRETE TRANSITION SLAB
FOR BRICK MANHOLE RISER
OVER 48" PRECAST MANHOLE BASE

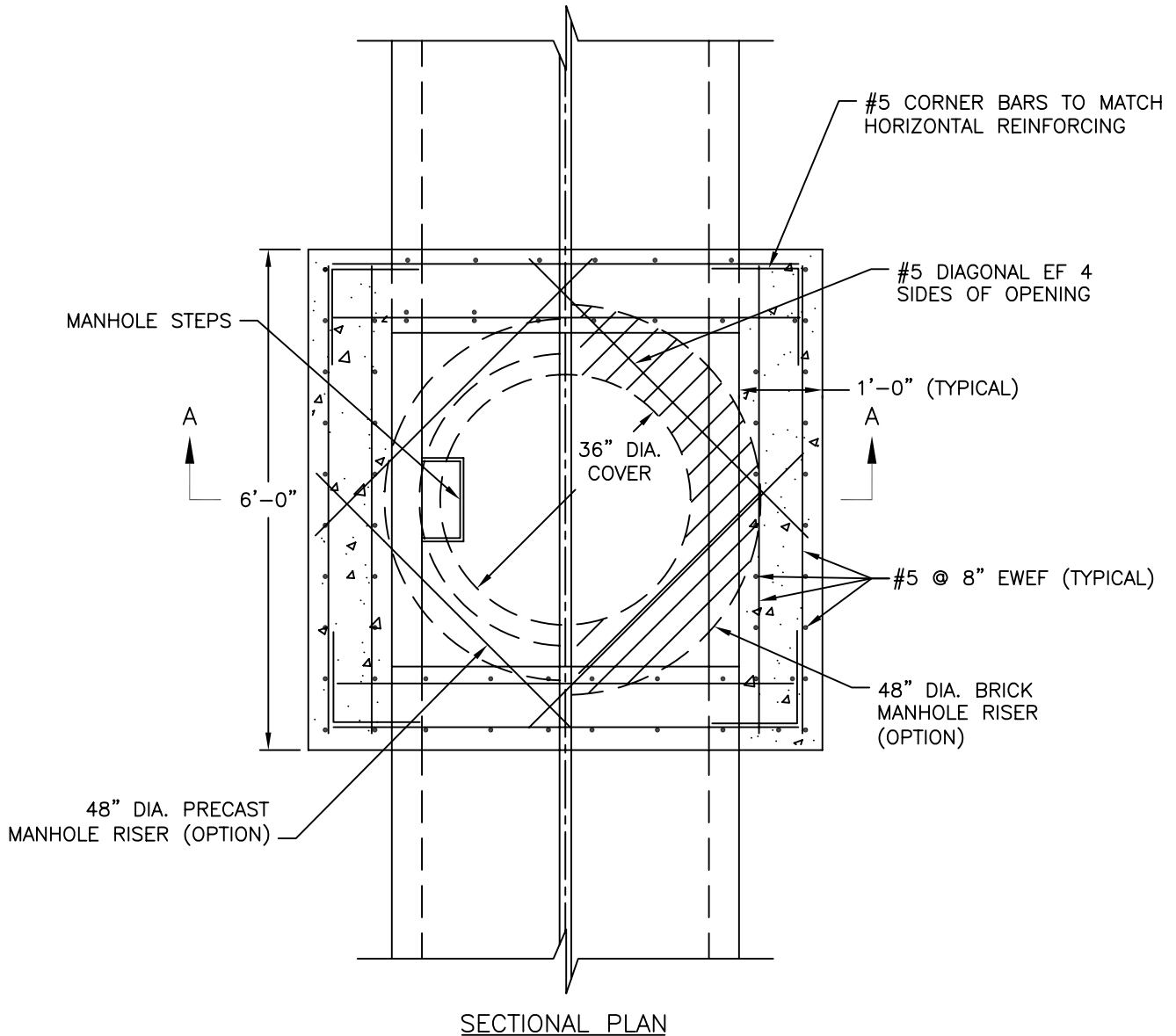

SECTIONAL PLAN

NOTES:

1. ALL CONCRETE TO BE CLASS 4,000 AIR ENTRAINED, TYPE II CEMENT.
2. REINFORCING STEEL SHALL CONFORM TO ASTM A615 GRADE 60.
3. FOR MANHOLES DEPTHS GREATER THAN 15' TO INVERT, USE 36" DIAMETER CAST IRON FRAME AND COVER. FOR MANHOLE DEPTHS EQUAL TO 15' OR LESS, USE A 36"X 24" ADAPTER RING WITH A 24" DIAMETER COVER.
4. MAXIMUM TOTAL DEPTH 20 FT.

SEWER DIAMETER	DIMENSION "A"	DIMENSION "B"
33" THRU 36"	4'-0"	7'-2"
42"	4'-3"	7'-10 1/4"
48"	4'-10"	8'-4"

APPROVED DATE: June 20, 2003

DIRECTOR, DEPARTMENT OF ENGINEERING
AND TECHNICAL SERVICES

REVISION NO.: 0
DATE: 6/20/03
PREPARED BY: OBG/BKJV
CHECKED BY: W.DARROW

STANDARD DETAIL
CAST IN PLACE CONCRETE MANHOLE BASE
FOR NEW 33" THRU 48" DIAMETER SEWERS
WITH PIPE OR BRICK RISER OPTIONS

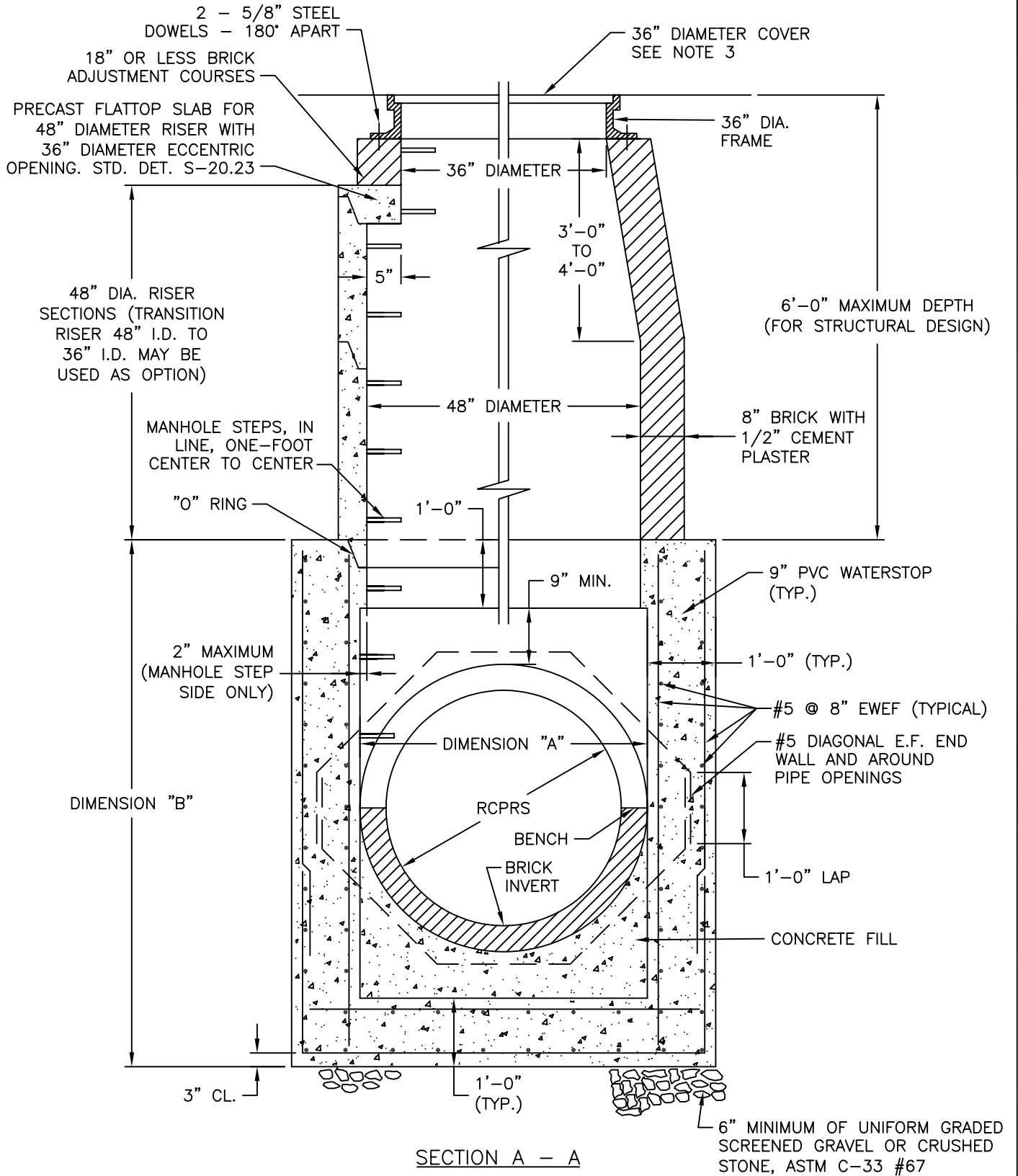

APPROVED DATE: June 20, 2003

DIRECTOR, DEPARTMENT OF ENGINEERING AND TECHNICAL SERVICES

REVISION NO.: 0
DATE: 6/20/03
PREPARED BY: OBG/BKJV
CHECKED BY: W.DARROW

STANDARD DETAIL
CAST IN PLACE CONCRETE MANHOLE BASE
FOR NEW 33" THRU 48" DIAMETER SEWERS
WITH PIPE OR BRICK RISER OPTIONS

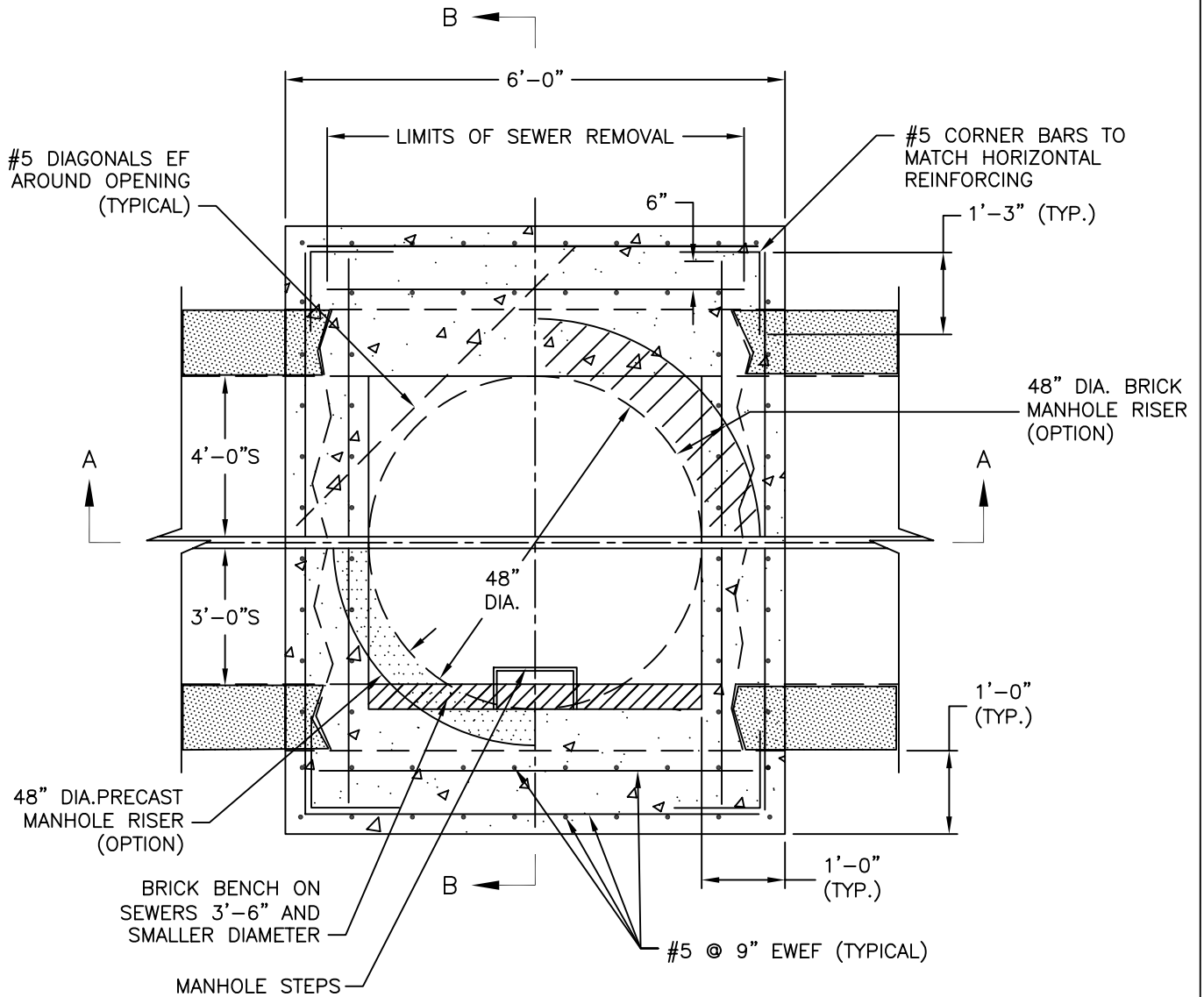

SECTIONAL PLAN

NOTES:

1. ALL CONCRETE TO BE CLASS 4000, AIR ENTRAINED, TYPE II CEMENT.
2. REINFORCING STEEL SHALL CONFORM TO ASTM A615, GRADE 60.
3. FOR MANHOLE DEPTHS GREATER THAN 15' TO INVERT, USE 36" DIAMETER CAST IRON FRAME AND COVER. FOR MANHOLE DEPTHS EQUAL TO 15' OR LESS, USE A 36"X 24" ADAPTER RING WITH A 24" DIAMETER COVER.
4. MAXIMUM DEPTH 20 FT.

APPROVED DATE: June 20, 2003

DIRECTOR, DEPARTMENT OF ENGINEERING
 AND TECHNICAL SERVICES

REVISION NO.: 0
 DATE: 6/20/03
 PREPARED BY: OBG/BKJV
 CHECKED BY: W.DARROW

STANDARD DETAIL
 CAST IN PLACE CONCRETE MANHOLE BASE
 ON EXISTING 3-FOOT TO 4-FOOT DIAMETER
 CONCRETE MASONRY SEWERS

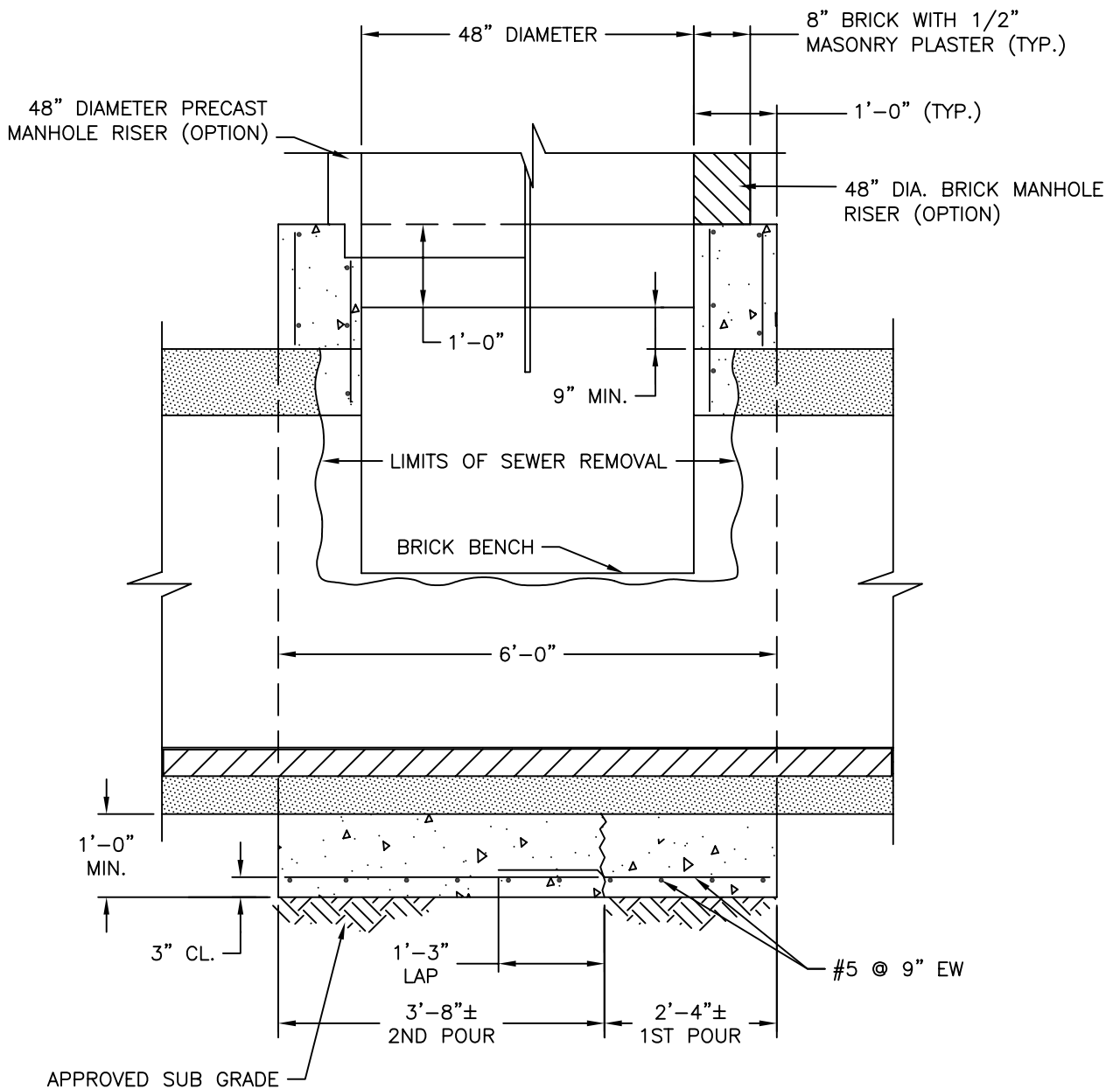

SECTION A-A

NOTE:

FIRST POUR SHALL BE ALLOWED TO CURE A MINIMUM 24 HOURS PRIOR TO EXCAVATING AND PLACING SECOND POUR.

APPROVED DATE: June 20, 2003

DIRECTOR, DEPARTMENT OF ENGINEERING AND TECHNICAL SERVICES

REVISION NO.: 0
 DATE: 6/20/03
 PREPARED BY: OBG/BKJV
 CHECKED BY: W.DARROW

STANDARD DETAIL
 CAST IN PLACE CONCRETE MANHOLE BASE
 ON EXISTING 3-FOOT TO 4-FOOT DIAMETER
 CONCRETE MASONRY SEWERS

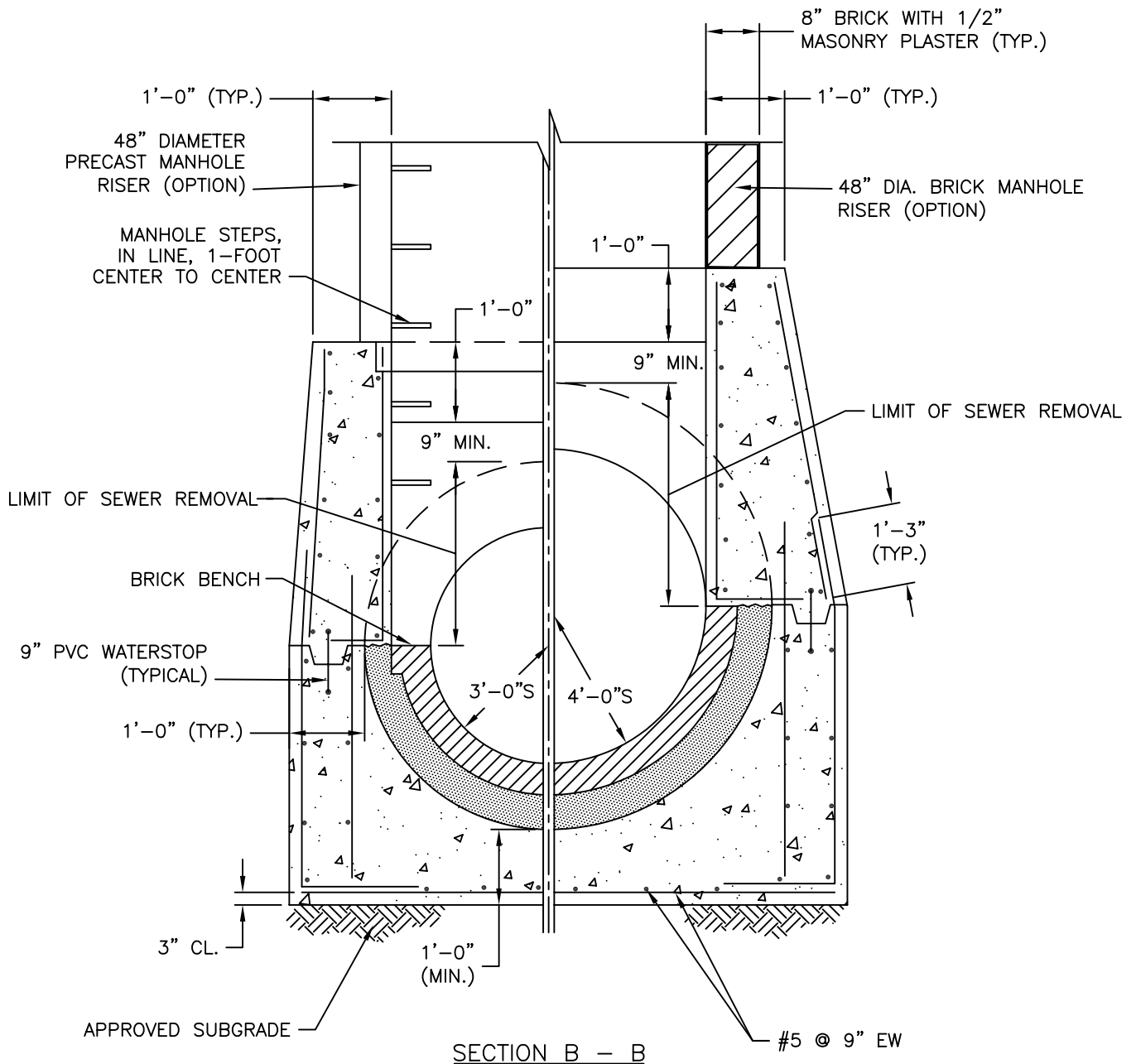

APPROVED DATE: June 20, 2003

DIRECTOR, DEPARTMENT OF ENGINEERING
 AND TECHNICAL SERVICES

REVISION NO.: 0
 DATE: 6/20/03
 PREPARED BY: OBG/BKJV
 CHECKED BY: W.DARROW

STANDARD DETAIL
 CAST IN PLACE CONCRETE MANHOLE BASE
 ON EXISTING 3-FOOT TO 4-FOOT DIAMETER
 CONCRETE MASONRY SEWERS

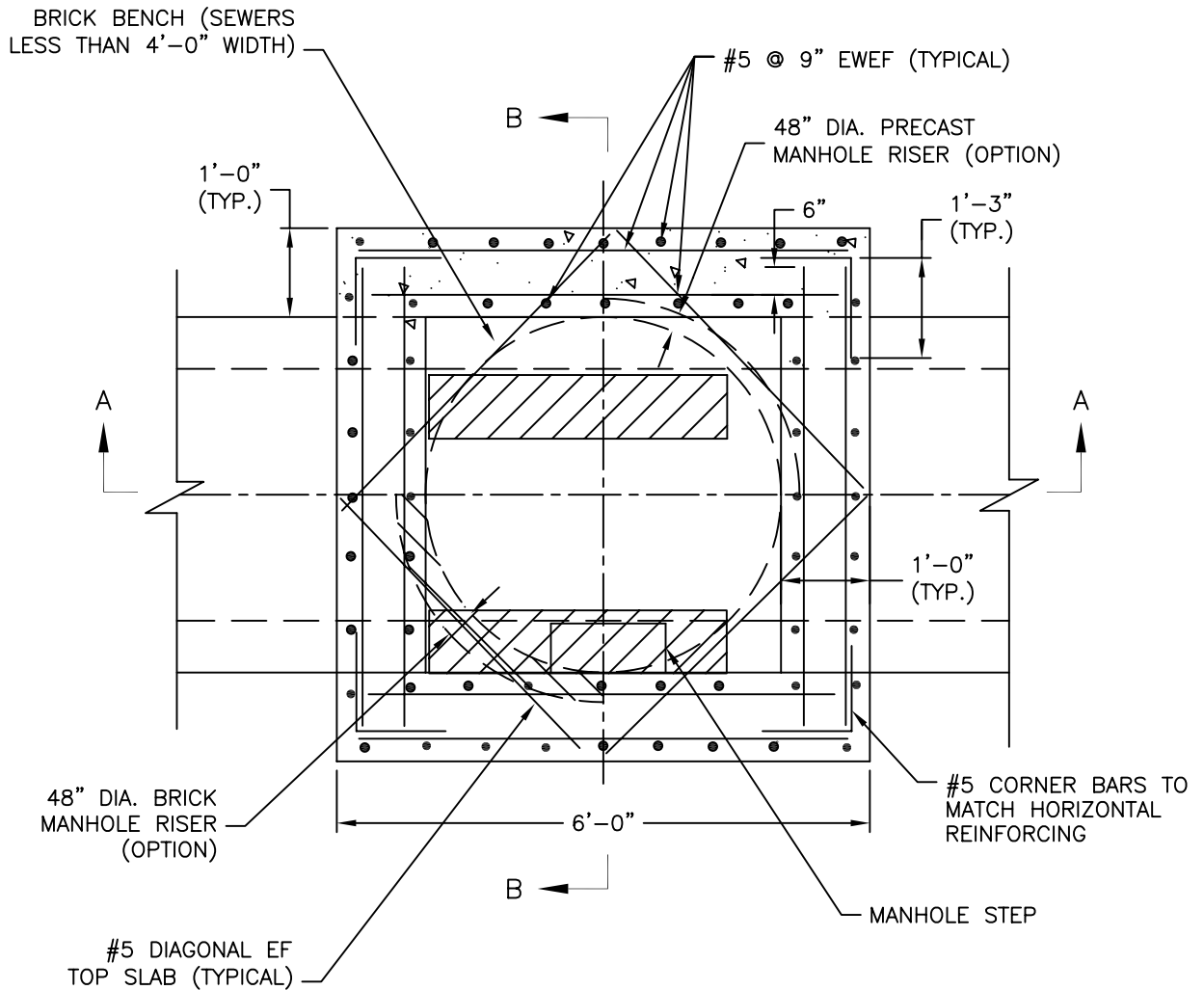

SECTIONAL PLAN

NOTES:

1. ALL CONCRETE TO BE CLASS 4000 AIR ENTRAINED, TYPE II CEMENT.
2. REINFORCING STEEL SHALL CONFORM TO ASTM A-615 GRADE 60
3. FOR MANHOLE DEPTHS GREATER THAN 15' TO INVERT, USE 36" DIAMETER CAST IRON FRAME AND COVER. FOR MANHOLE DEPTHS EQUAL TO 15' OR LESS, USE A 36" X 24" ADAPTER RING WITH A 24" DIAMETER COVER.
4. MAXIMUM DEPTH 20 FT.

APPROVED DATE: June 20, 2003

DIRECTOR, DEPARTMENT OF ENGINEERING AND TECHNICAL SERVICES

REVISION NO.: 0
 DATE: 6/20/03
 PREPARED BY: OBG/BKJV
 CHECKED BY: W.DARROW

STANDARD DETAIL
 CAST IN PLACE CONCRETE MANHOLE BASE
 ON EXISTING 2'-0" X 3'-0" THRU 4'-0" X 6'-0"
 EGG - SHAPED SEWERS

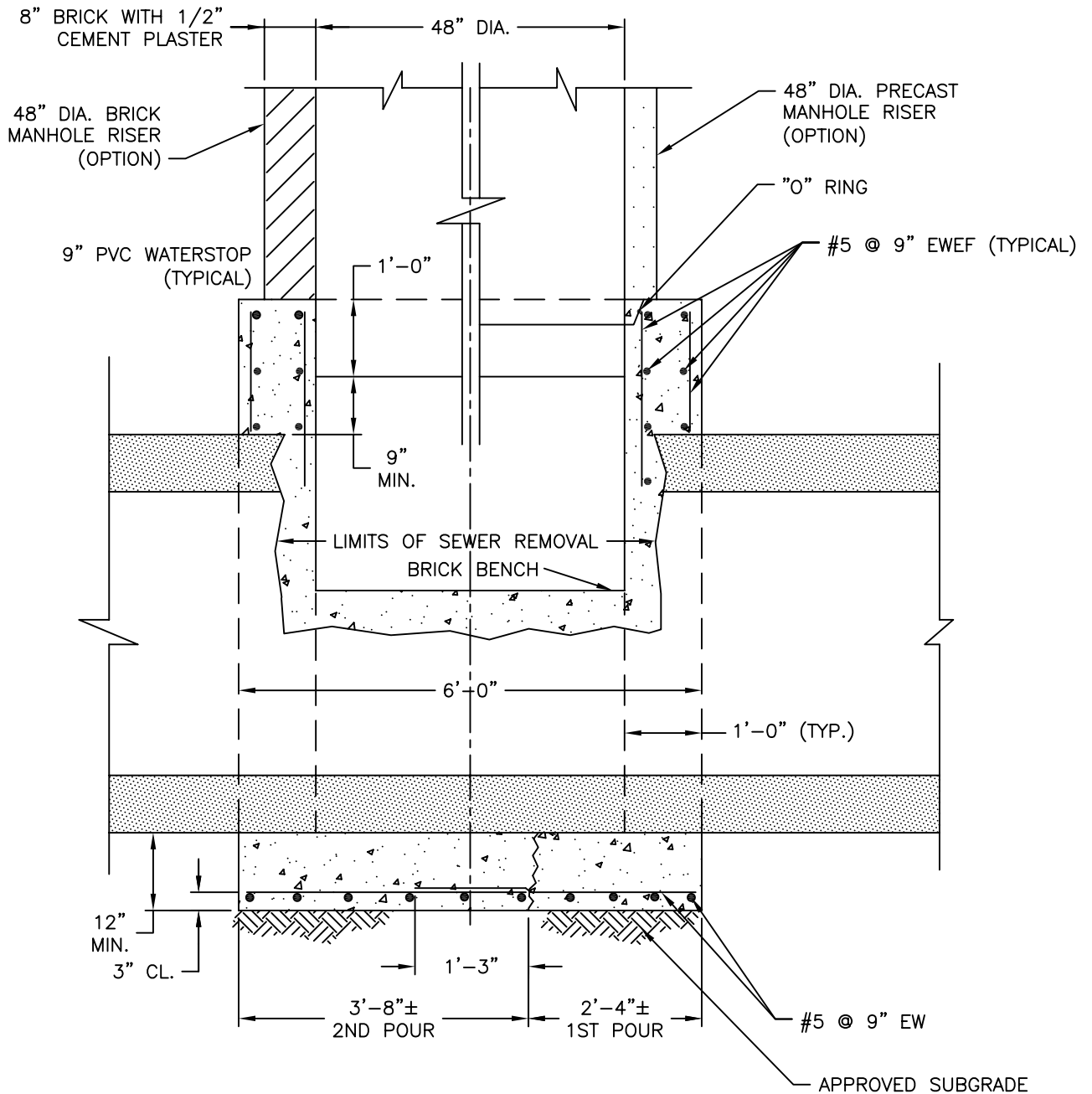

SECTION A-A

NOTE:

FIRST POUR SHALL BE ALLOWED TO CURE A MINIMUM 24 HOURS PRIOR TO EXCAVATING AND PLACING SECOND POUR.

APPROVED DATE: June 20, 2003

DIRECTOR, DEPARTMENT OF ENGINEERING
AND TECHNICAL SERVICES

REVISION NO.: 0
DATE: 6/20/03
PREPARED BY: OBG/BKJV
CHECKED BY: W.DARROW

STANDARD DETAIL
CAST IN PLACE CONCRETE MANHOLE BASE
ON EXISTING 2'-0" X 3'-0" THRU 4'-0" X 6'-0"
EGG - SHAPED SEWERS

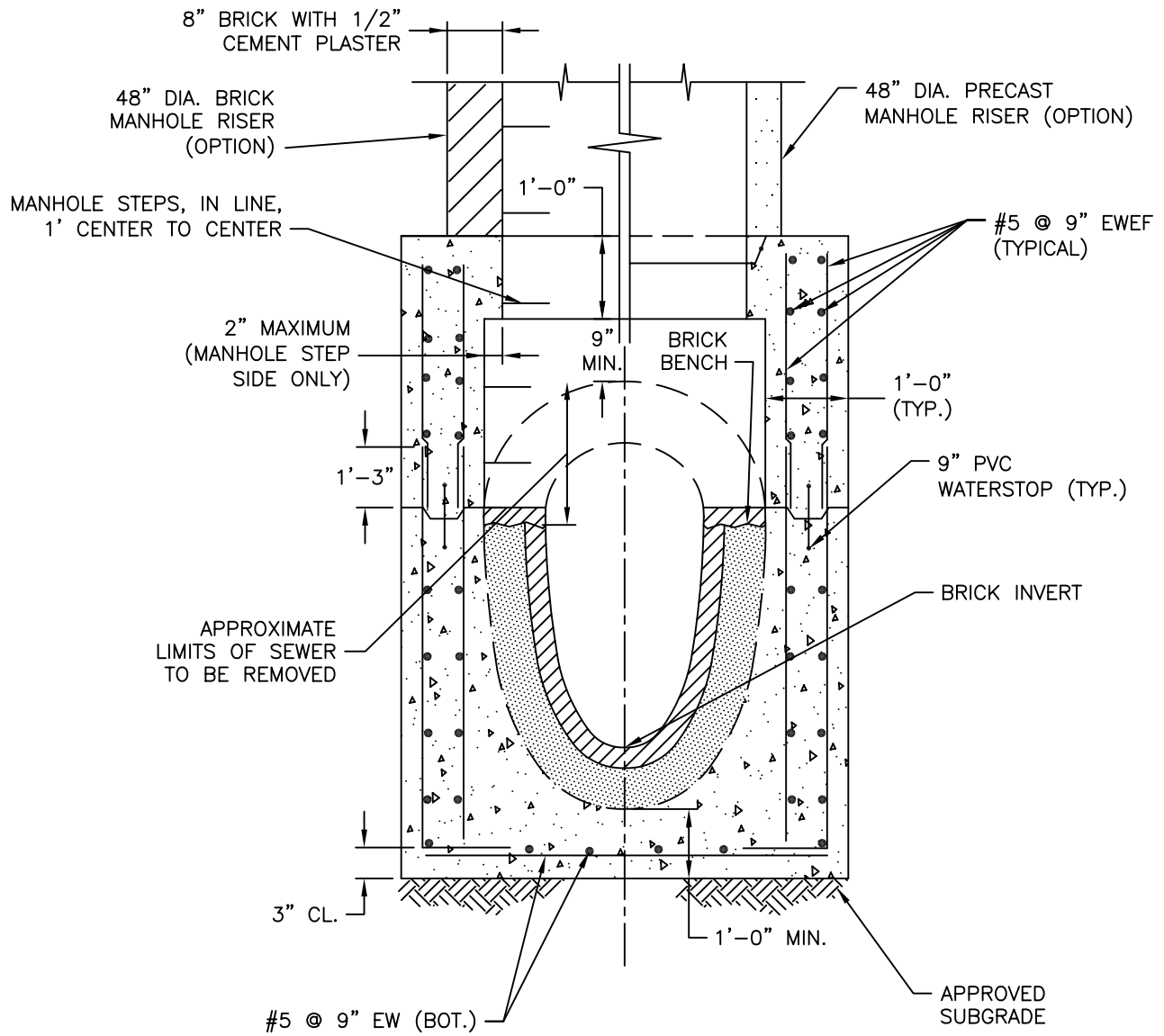

SECTION B-B

APPROVED DATE: June 20, 2003

DIRECTOR, DEPARTMENT OF ENGINEERING
AND TECHNICAL SERVICES

REVISION NO.: 0
DATE: 6/20/03
PREPARED BY: OBG/BKJV
CHECKED BY: W.DARROW

STANDARD DETAIL
CAST IN PLACE CONCRETE MANHOLE BASE
ON EXISTING 2'-0" X 3'-0" THRU 4'-0" X 6'-0"
EGG - SHAPED SEWERS

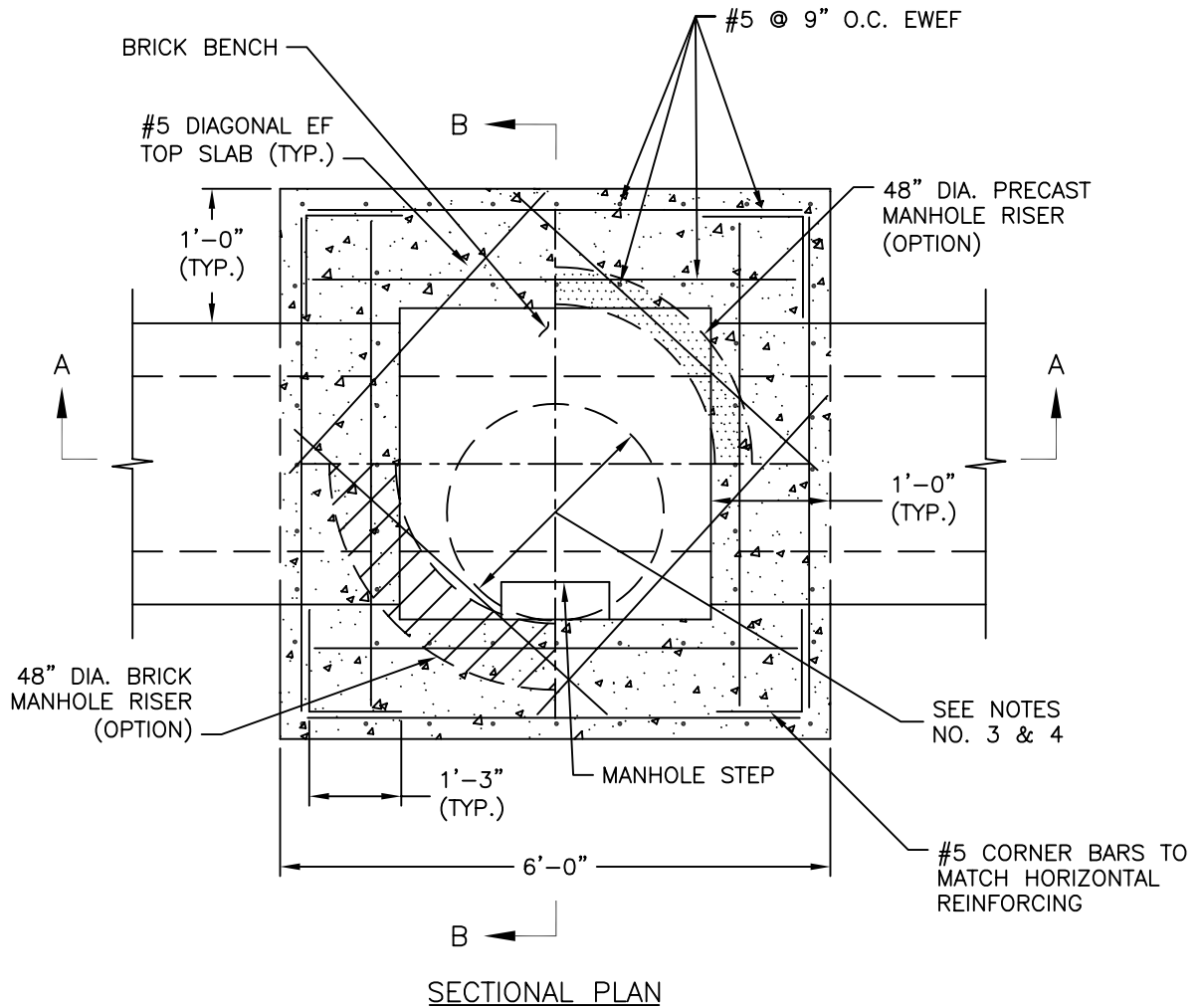

NOTES:

1. ALL CONCRETE TO BE CLASS 4000, AIR ENTRAINED, TYPE II CEMENT
2. REINFORCING STEEL SHALL CONFORM TO ASTM A-615 GRADE 60
3. FOR DEPTHS 15 FT. OR LESS TO INVERT USE 36"x24" ADAPTER RING WITH 24" DIAMETER COVER
4. FOR DEPTHS 15'-6" OR GREATER, USE 36" DIAMETER COVER
5. MAXIMUM DEPTH 20 FT.

APPROVED DATE: June 20, 2003

DIRECTOR, DEPARTMENT OF ENGINEERING
AND TECHNICAL SERVICES

REVISION NO.: 0
DATE: 6/20/03
PREPARED BY: OBG/BKJV
CHECKED BY: W.DARROW

STANDARD DETAIL
CAST IN PLACE CONCRETE MANHOLE BASE
ON EXISTING
2'-0" X 3'-0" SEWERS

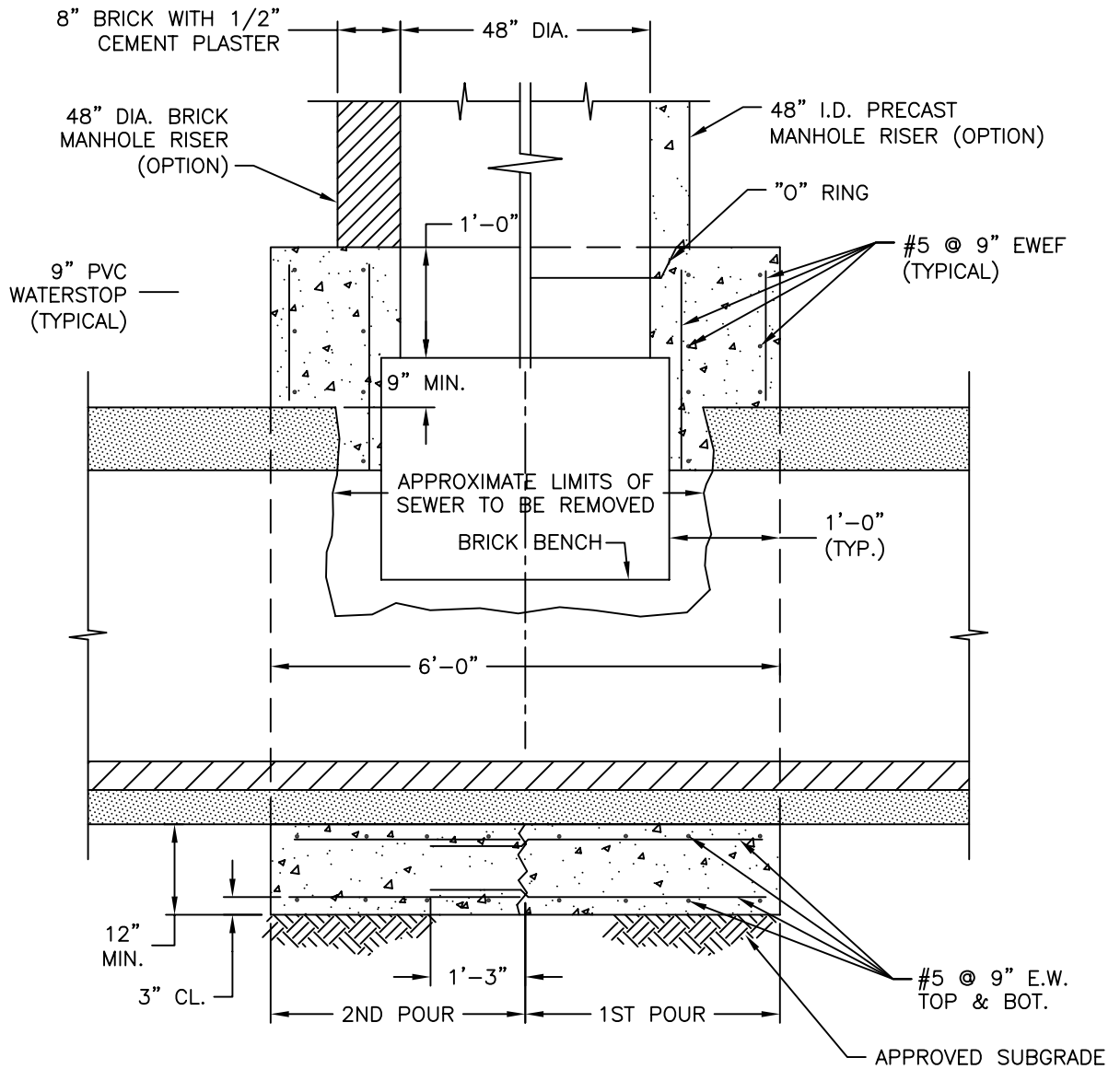

SECTION A-A

NOTE:

FIRST POUR SHALL BE ALLOWED TO CURE A MINIMUM 24 HOURS PRIOR TO EXCAVATING AND PLACING SECOND POUR.

APPROVED DATE: June 20, 2003

DIRECTOR, DEPARTMENT OF ENGINEERING AND TECHNICAL SERVICES

REVISION NO.: 0
 DATE: 6/20/03
 PREPARED BY: OBG/BKJV
 CHECKED BY: W.DARROW

STANDARD DETAIL
 CAST IN PLACE CONCRETE MANHOLE BASE
 ON EXISTING
 2'-0" X 3'-0" SEWERS

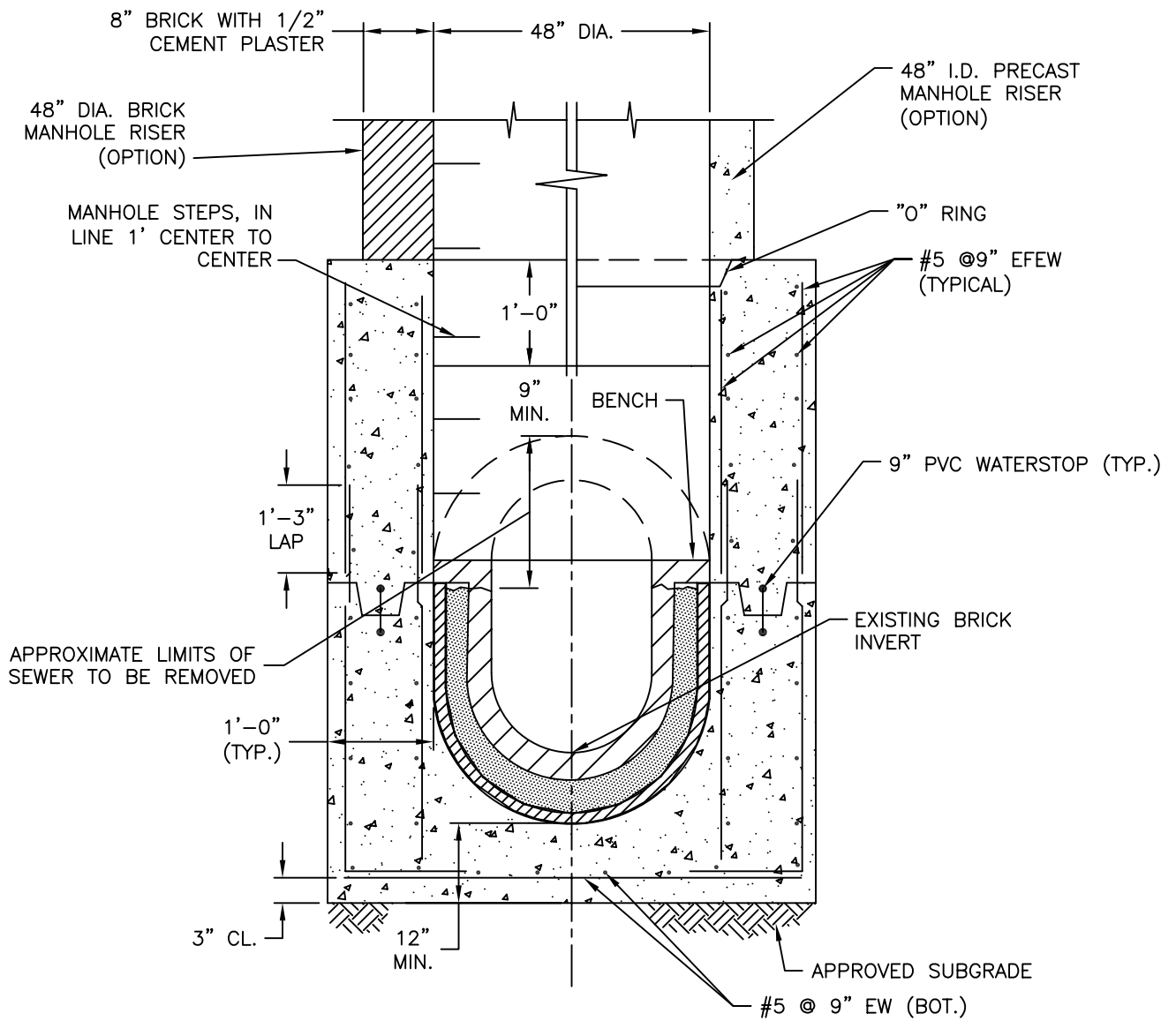

SECTION B-B

APPROVED DATE: June 20, 2003

DIRECTOR, DEPARTMENT OF ENGINEERING
 AND TECHNICAL SERVICES

REVISION NO.: 0
 DATE: 6/20/03
 PREPARED BY: OBG/BKJV
 CHECKED BY: W.DARROW

STANDARD DETAIL
 CAST IN PLACE CONCRETE MANHOLE BASE
 ON EXISTING
 2'-0" X 3'-0" SEWERS

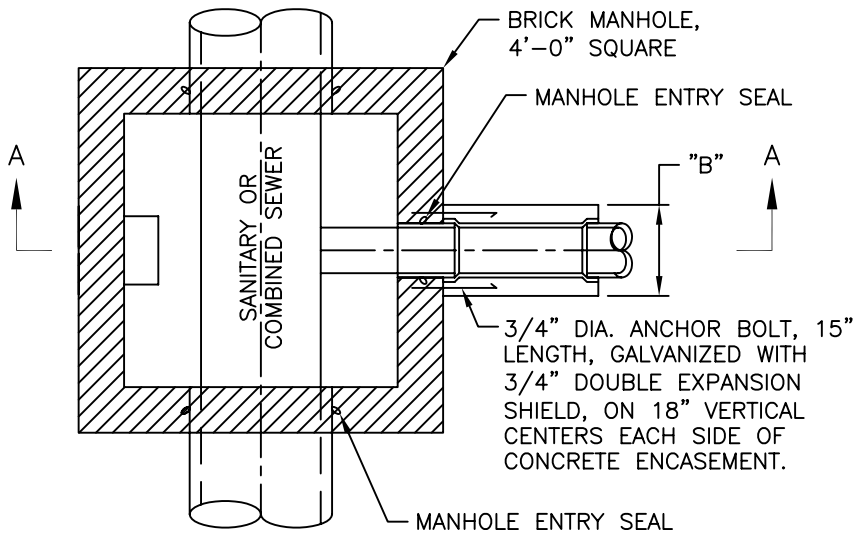

SECTIONAL PLAN
BRICK MANHOLE

SEWER OR LATERAL DIAMETER	STACK PIPE DIAMETER	DIMENSIONS "A" & "B"
4"	4"	16"
6"	6"	18"
8"	8"	20"
10"	10"	22"
12"	10"	22"
15"	12"	24"
18"	15"	27"
21"	18"	30"
24"	21"	33"

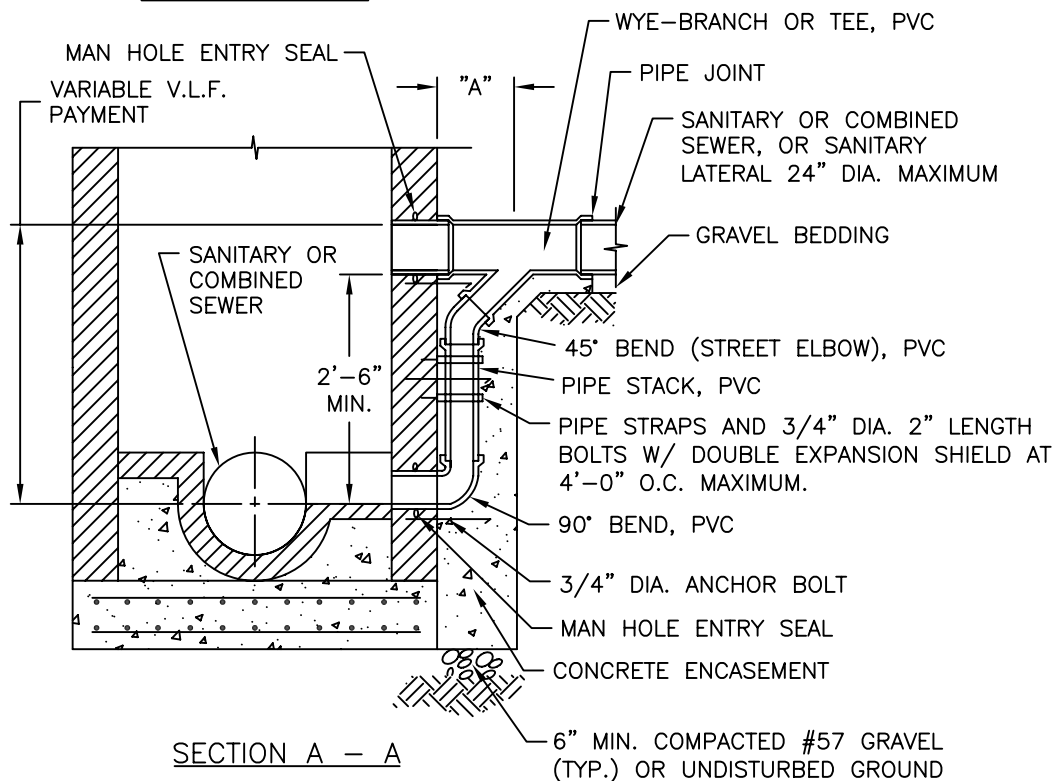

SECTION A - A

NOTES:

1. OUTSIDE FLOW DIVERTER SHALL BE USED FOR ALL DROP MANHOLES UNLESS OTHERWISE SPECIFIED OR SHOWN ON DRAWINGS
2. IF APPROVED BY WASA, WHEN THE DISTANCE BETWEEN THE INVERT OF THE MANHOLE AND THE TOP OF OF THE BENCH IS LESS THAN 2'-6", THE STACK PIPE CAN BE INSTALLED AT THE TOP OF THE BENCH
3. ALL CONCRETE TO BE CLASS 4000, AIR ENTRAINED, TYPE II CEMENT.

APPROVED DATE: June 20, 2003

DIRECTOR, DEPARTMENT OF ENGINEERING
AND TECHNICAL SERVICES

REVISION NO.: 0
DATE: 6/20/03
PREPARED BY: OBG/BKJV
CHECKED BY: W.DARROW

STANDARD DETAIL
BRICK
DROP MANHOLE
FLOW DIVERT OUTSIDE

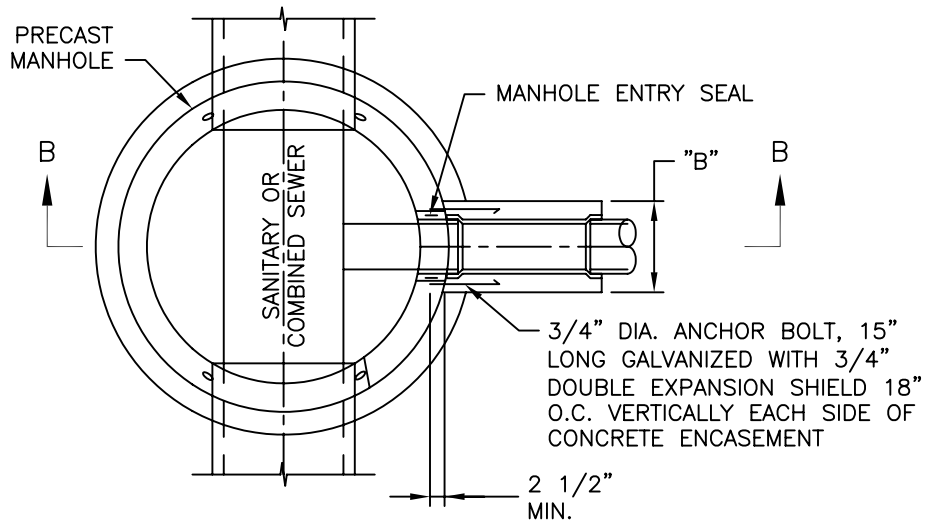

SECTIONAL PLAN
PRECAST MANHOLE

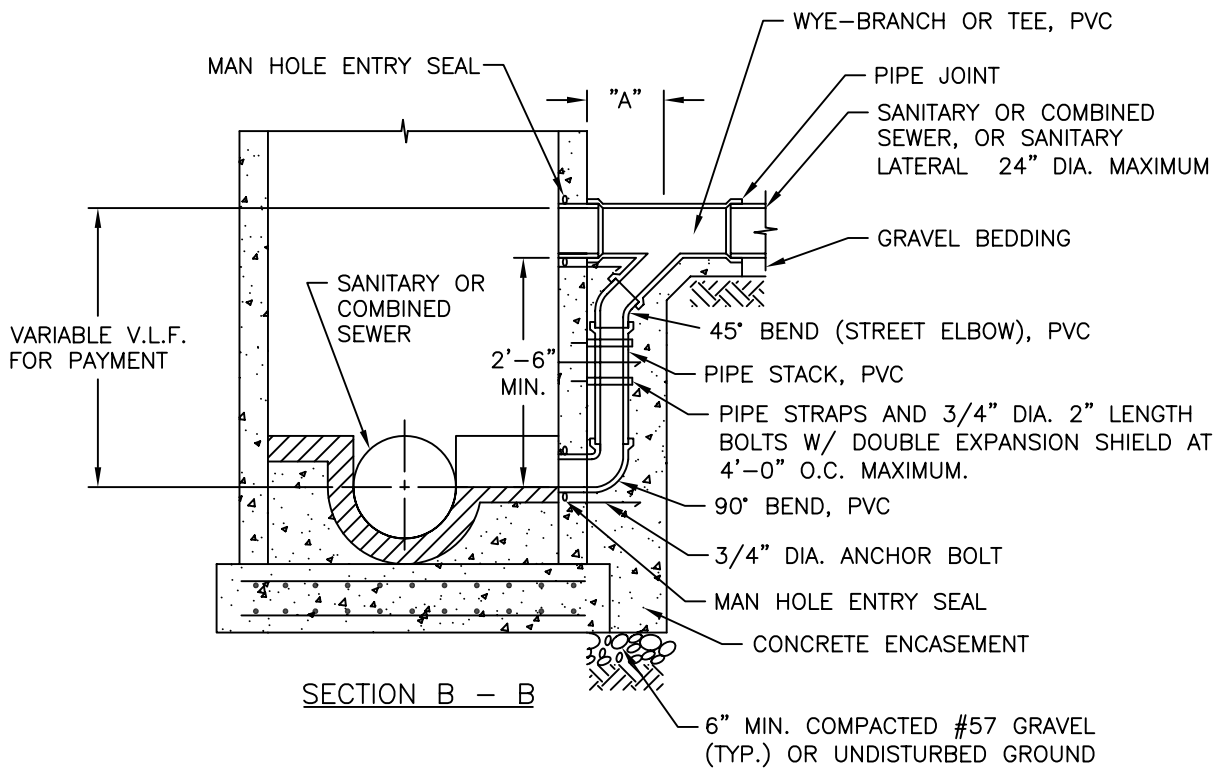

SECTION B - B

APPROVED DATE: June 20, 2003

DIRECTOR, DEPARTMENT OF ENGINEERING
AND TECHNICAL SERVICES

REVISION NO.: 0
DATE: 6/20/03
PREPARED BY: PRECAST
CHECKED BY: W.DARROW

STANDARD DETAIL
PRECAST
DROP MANHOLE
FLOW DIVERTER OUTSIDE

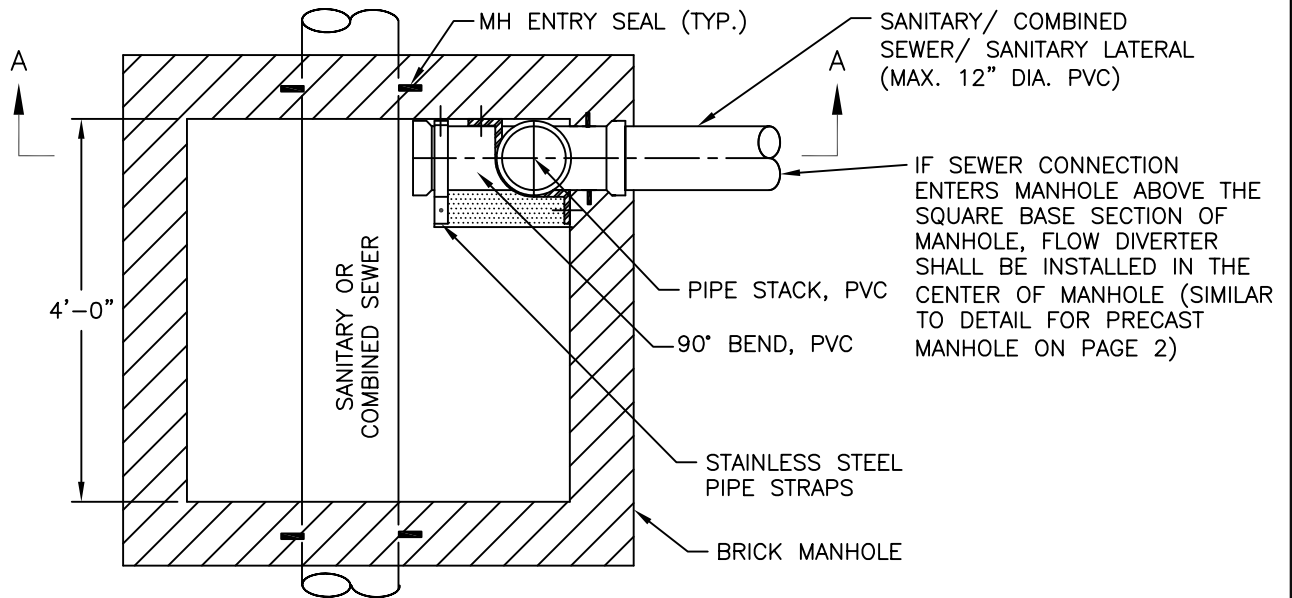

SECTIONAL PLAN
BRICK MANHOLE

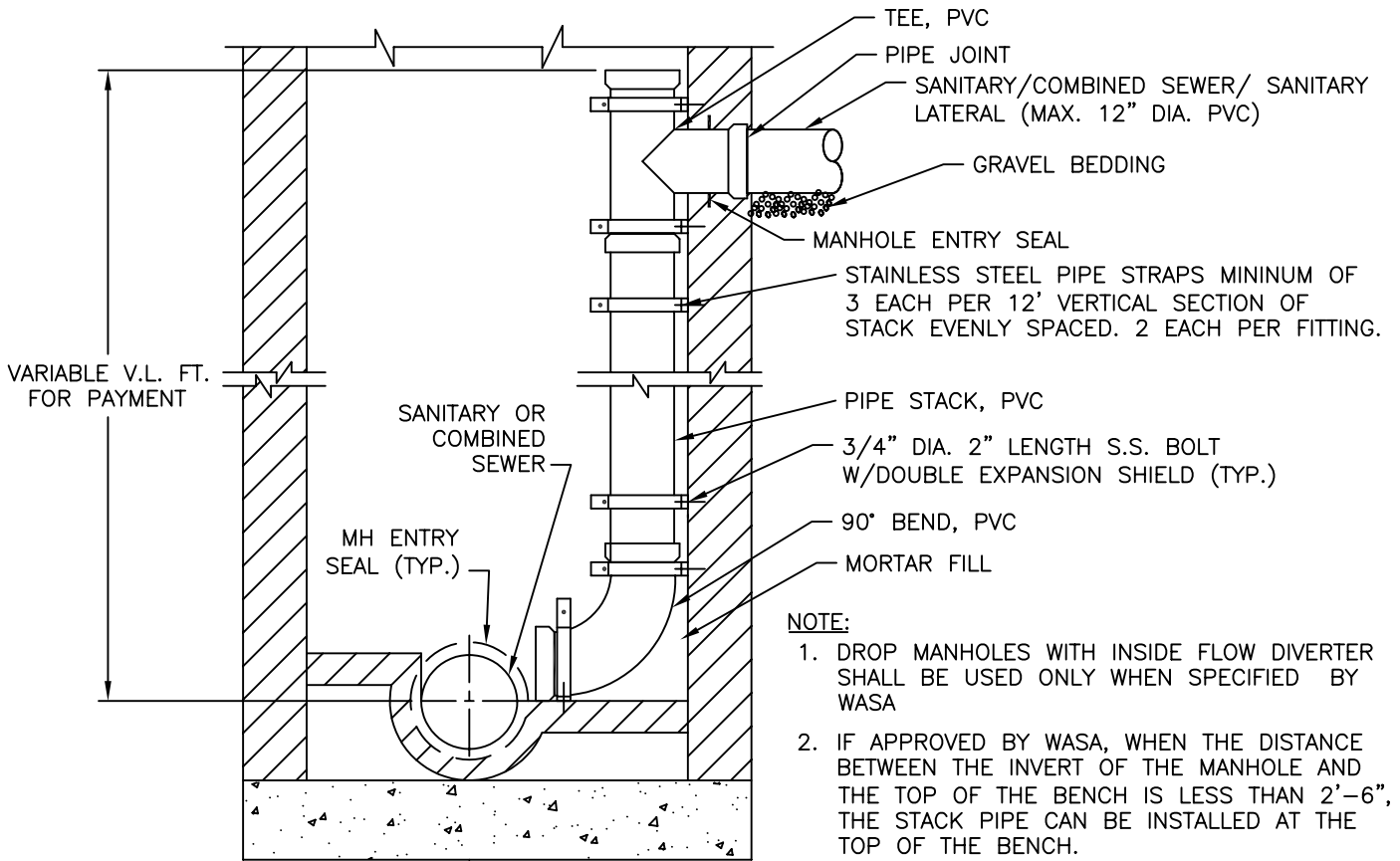

SECTION A - A

NOTE:

1. DROP MANHOLES WITH INSIDE FLOW DIVERTER SHALL BE USED ONLY WHEN SPECIFIED BY WASA
2. IF APPROVED BY WASA, WHEN THE DISTANCE BETWEEN THE INVERT OF THE MANHOLE AND THE TOP OF THE BENCH IS LESS THAN 2'-6", THE STACK PIPE CAN BE INSTALLED AT THE TOP OF THE BENCH.
3. ALL CONCRETE TO BE CLASS 4000, AIR ENTRAINED, TYPE II CEMENT.

APPROVED DATE: June 20, 2003

DIRECTOR, DEPARTMENT OF ENGINEERING
AND TECHNICAL SERVICES

REVISION NO.: 0
DATE: 6/20/03
PREPARED BY: OBG/BKJV
CHECKED BY: W.DARROW

STANDARD DETAIL

BRICK DROP MANHOLE
FLOW DIVERTER - INSIDE

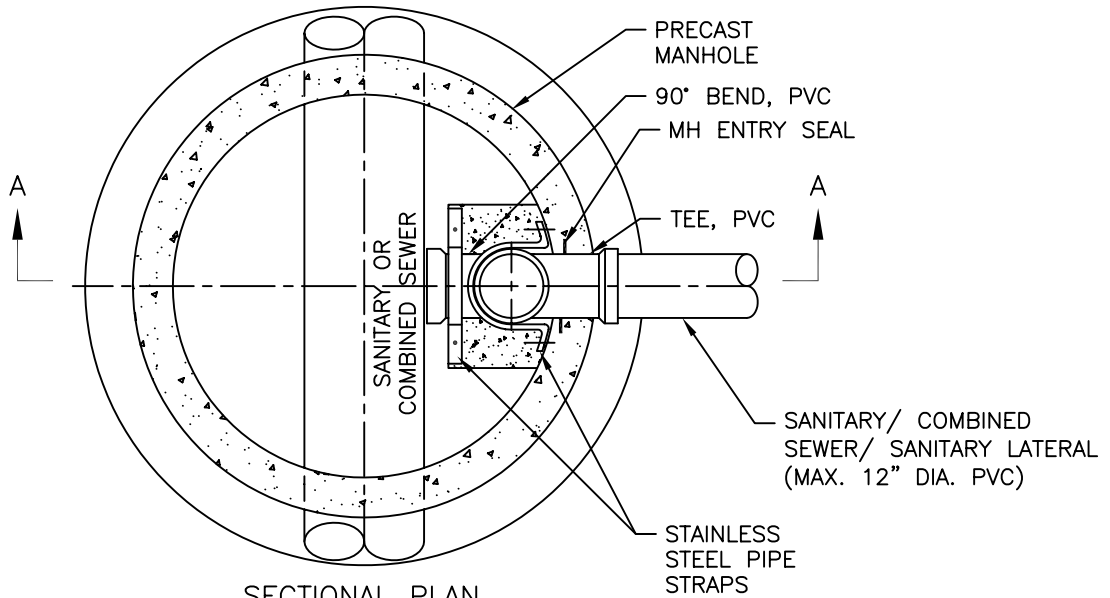

SECTIONAL PLAN
PRECAST MANHOLE

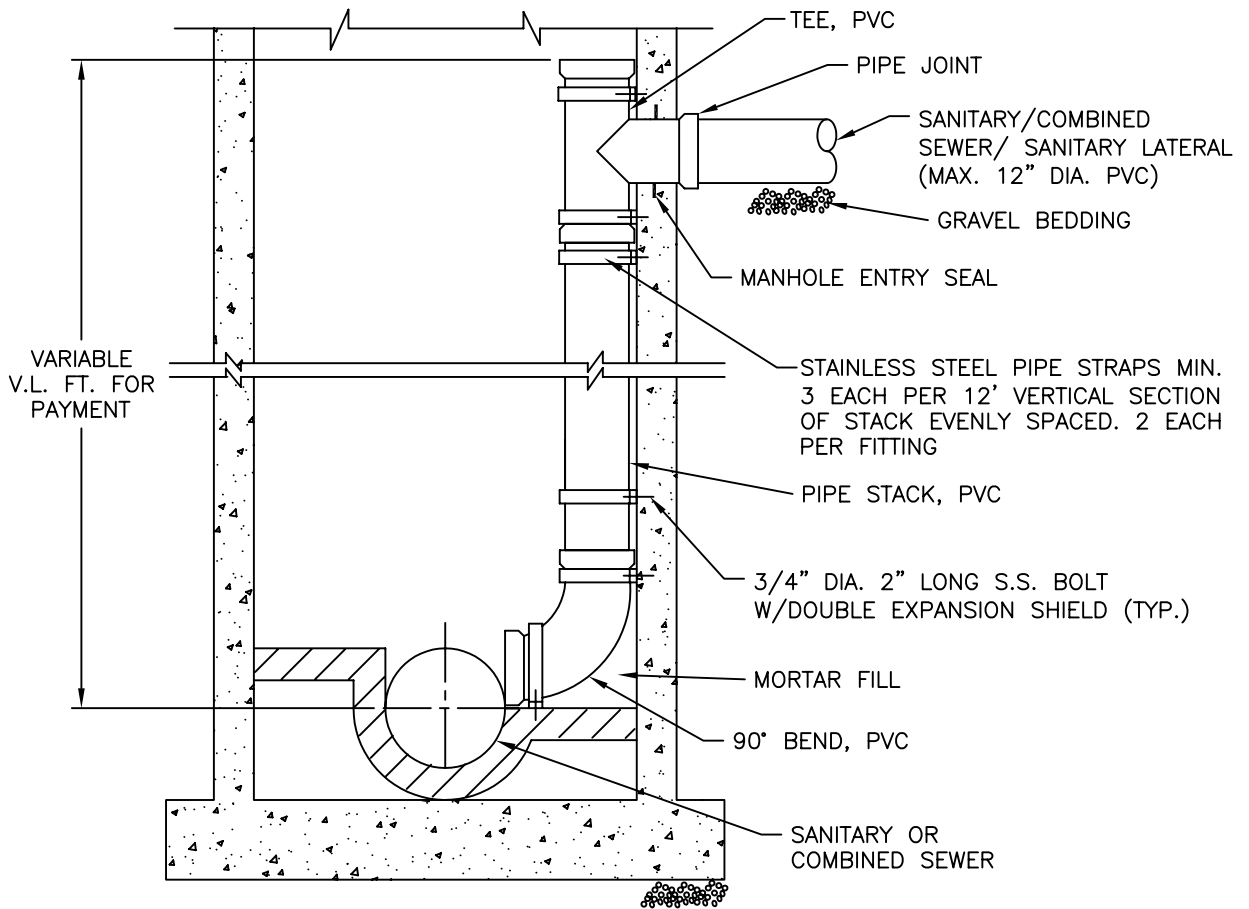

SECTION A - A

APPROVED DATE: June 20, 2003

DIRECTOR, DEPARTMENT OF ENGINEERING
AND TECHNICAL SERVICES

REVISION NO.: 0
DATE: 6/20/03
PREPARED BY: OBG/BKJV
CHECKED BY: W.DARROW

STANDARD DETAIL

DROP MANHOLE
FLOW DIVERTER - INSIDE

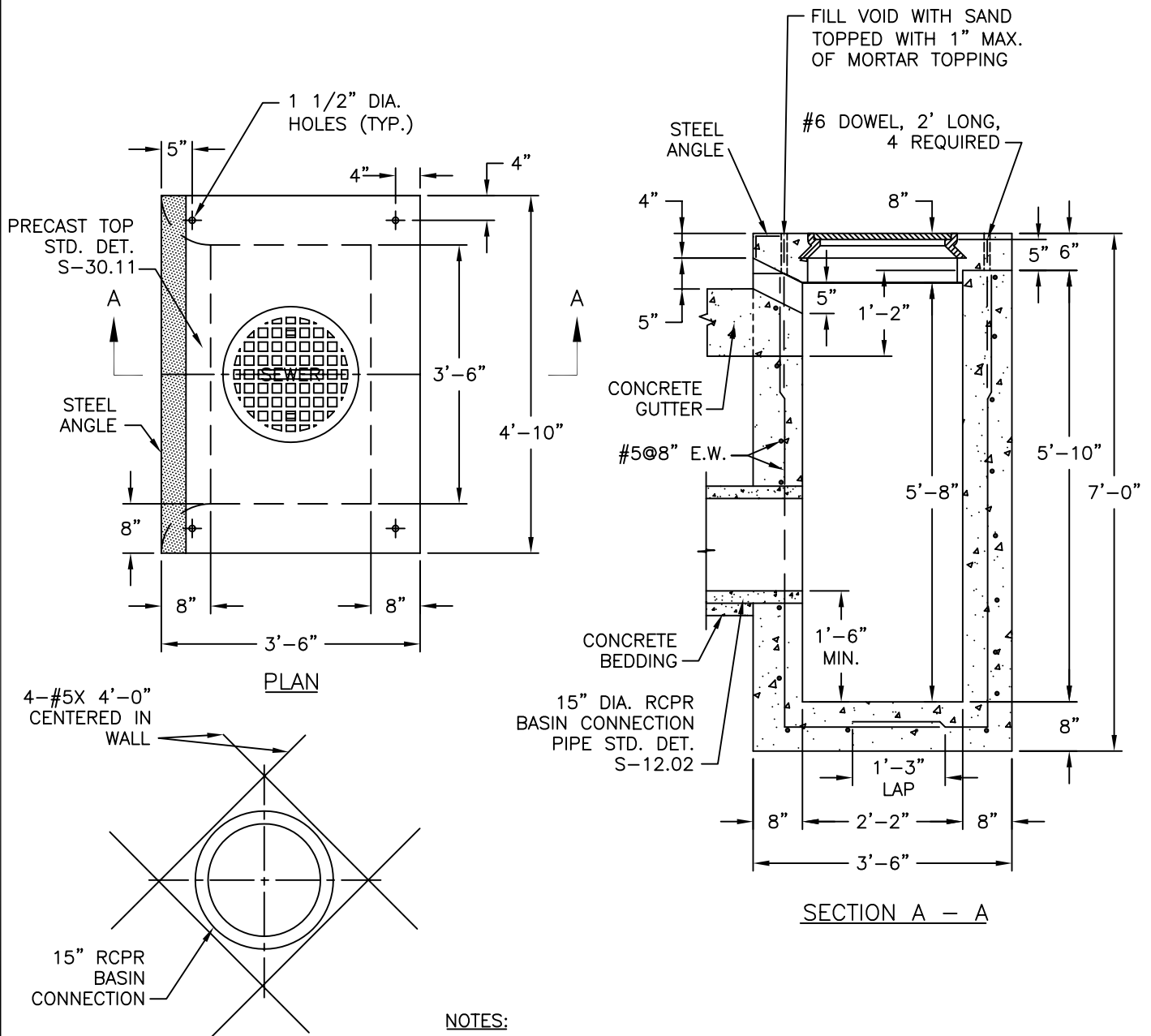

4-#5X 4'-0"
CENTERED IN
WALL

15" RCPR
BASIN
CONNECTION

ADD'L REINFORCING
AT OPENING

NOTES:

1. ALL CONCRETE TO BE CLASS 4000, AIR ENTRAINED, TYPE II CEMENT
2. REINFORCING SHALL BE CENTERED IN WALLS AND BASE AND SHALL CONFORM TO ASTM AC15 GRADE 60.

APPROVED DATE: June 20, 2003

DIRECTOR, DEPARTMENT OF ENGINEERING
AND TECHNICAL SERVICES

REVISION NO.: 0
DATE: 6/20/03
PREPARED BY: OBG/BKJV
CHECKED BY: W.DARROW

STANDARD DETAIL

STANDARD CATCH BASIN

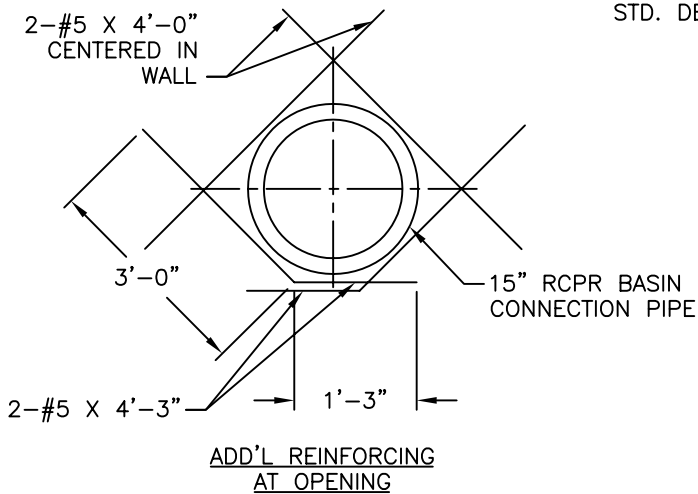
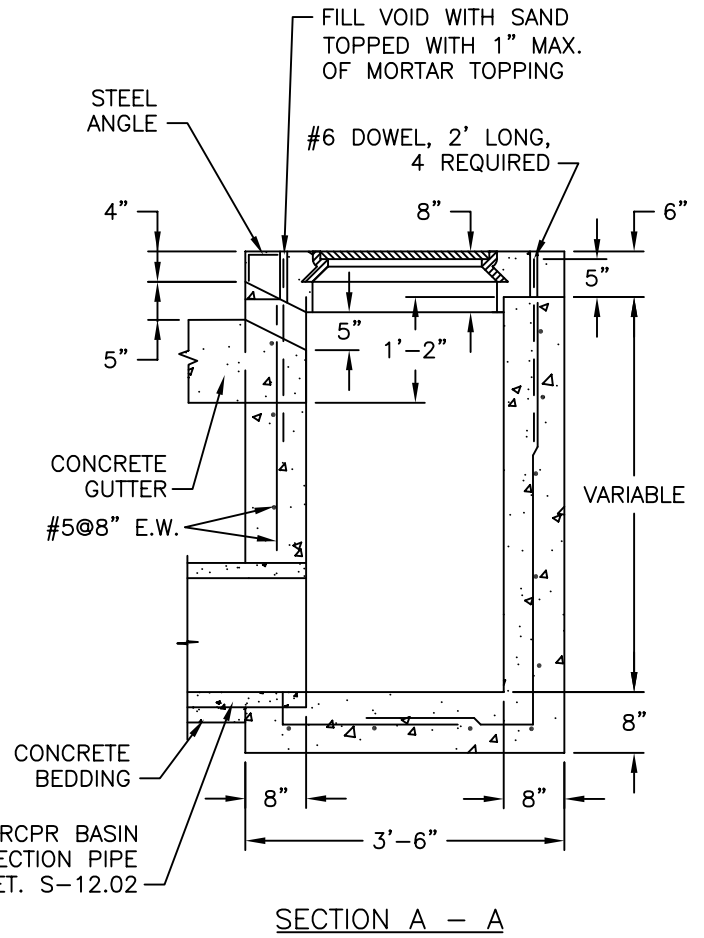
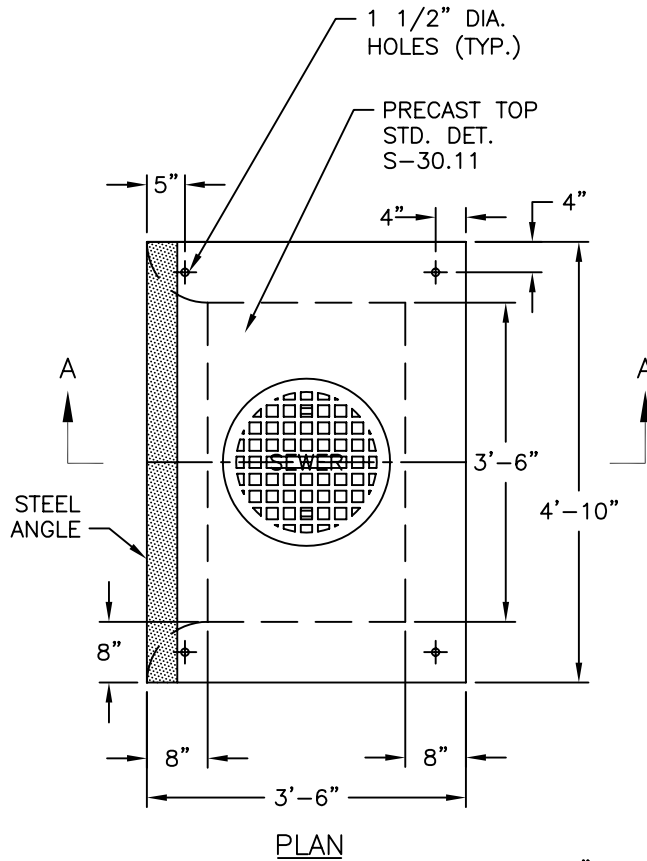

NOTES:

1. ALL CONCRETE TO BE CLASS 4000, AIR ENTRAINED, TYPE II CEMENT
2. REINFORCING SHALL BE CENTERED IN WALLS AND BASE, AND SHALL CONFORM TO ASTM A615 GRADE 60.

APPROVED DATE: June 20, 2003

DIRECTOR, DEPARTMENT OF ENGINEERING AND TECHNICAL SERVICES

REVISION NO.: 0
DATE: 6/20/03
PREPARED BY: OBG/BKJV
CHECKED BY: W.DARROW

STANDARD DETAIL

CATCH BASIN WITHOUT CATCHMENT CHAMBER

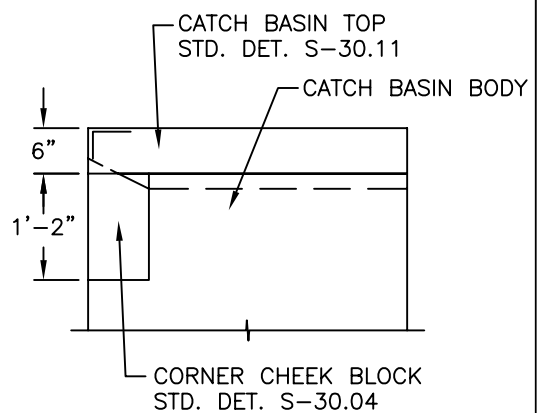
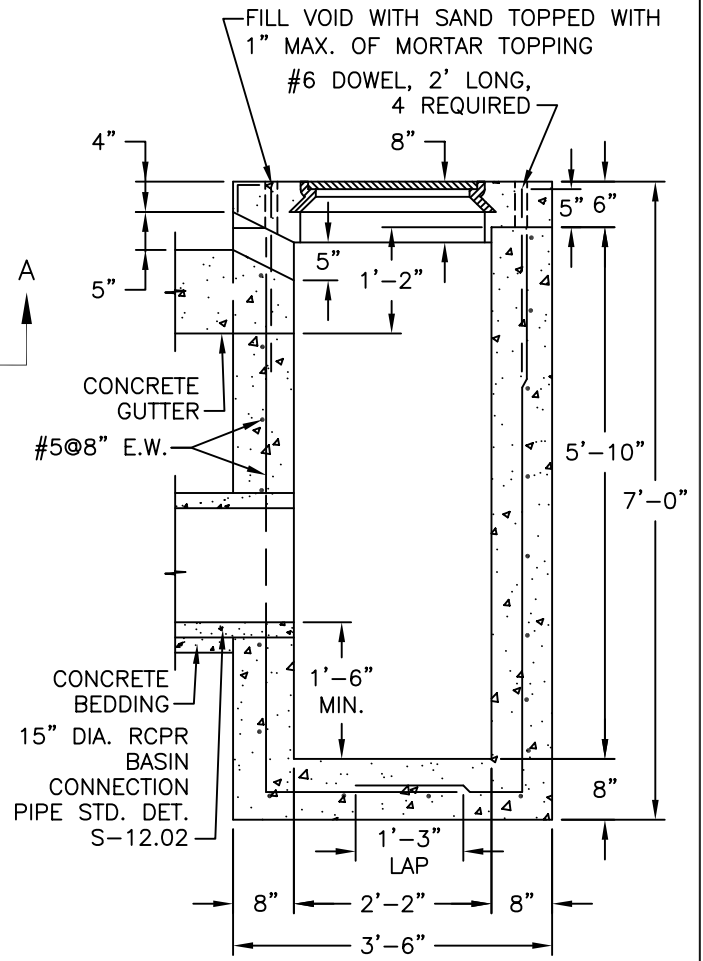
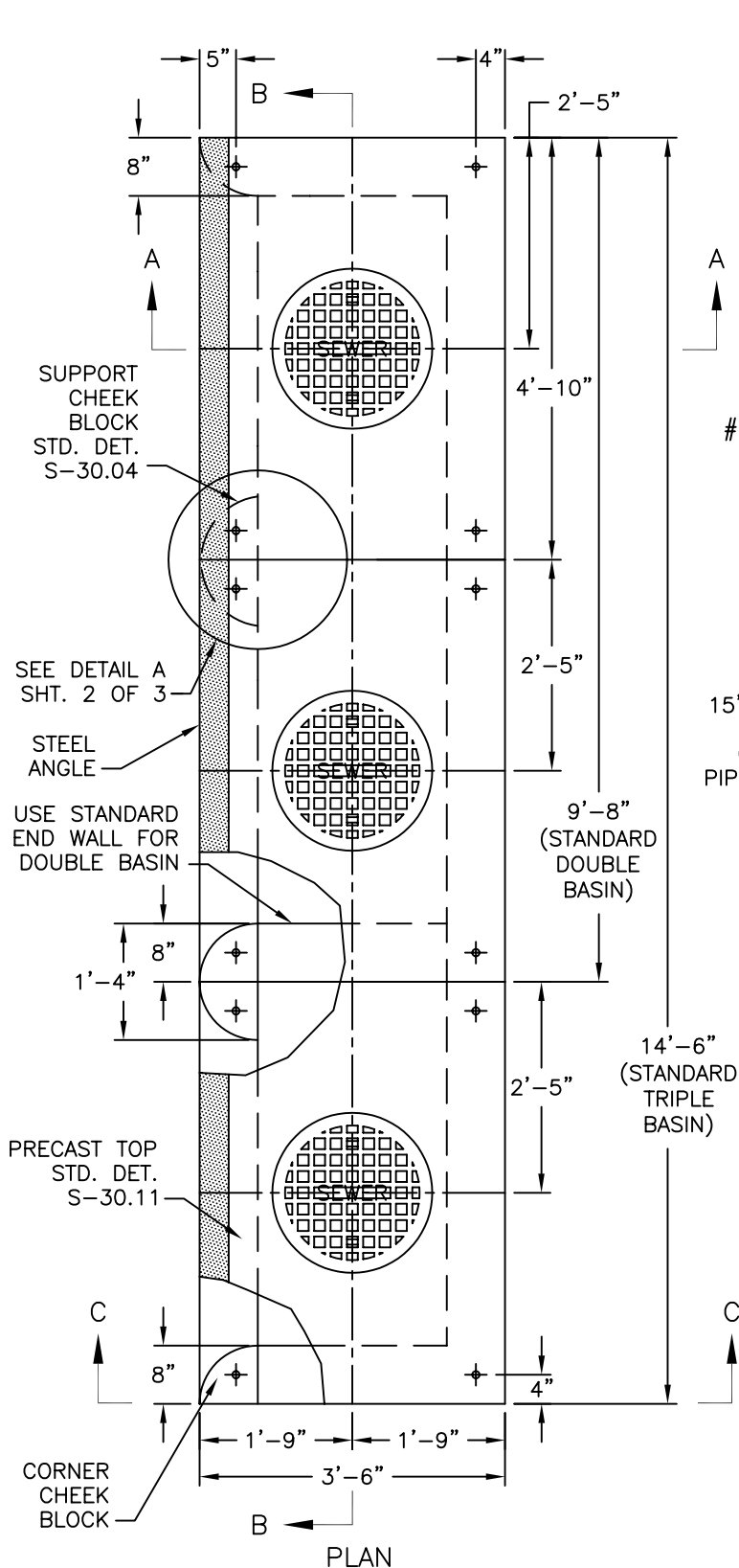

- NOTES:
1. ALL CONCRETE TO BE CLASS 4000, AIR ENTRAINED, TYPE II CEMENT.
 2. REINFORCING STEEL SHALL CONFORM TO ASTM A615, GRADE 60.

APPROVED DATE: June 20, 2003

DIRECTOR, DEPARTMENT OF ENGINEERING AND TECHNICAL SERVICES

REVISION NO.: 0

DATE: 6/20/03

PREPARED BY: OBG/BKJV

CHECKED BY: W.DARROW

STANDARD DETAIL

STANDARD DOUBLE AND STANDARD TRIPLE BASINS

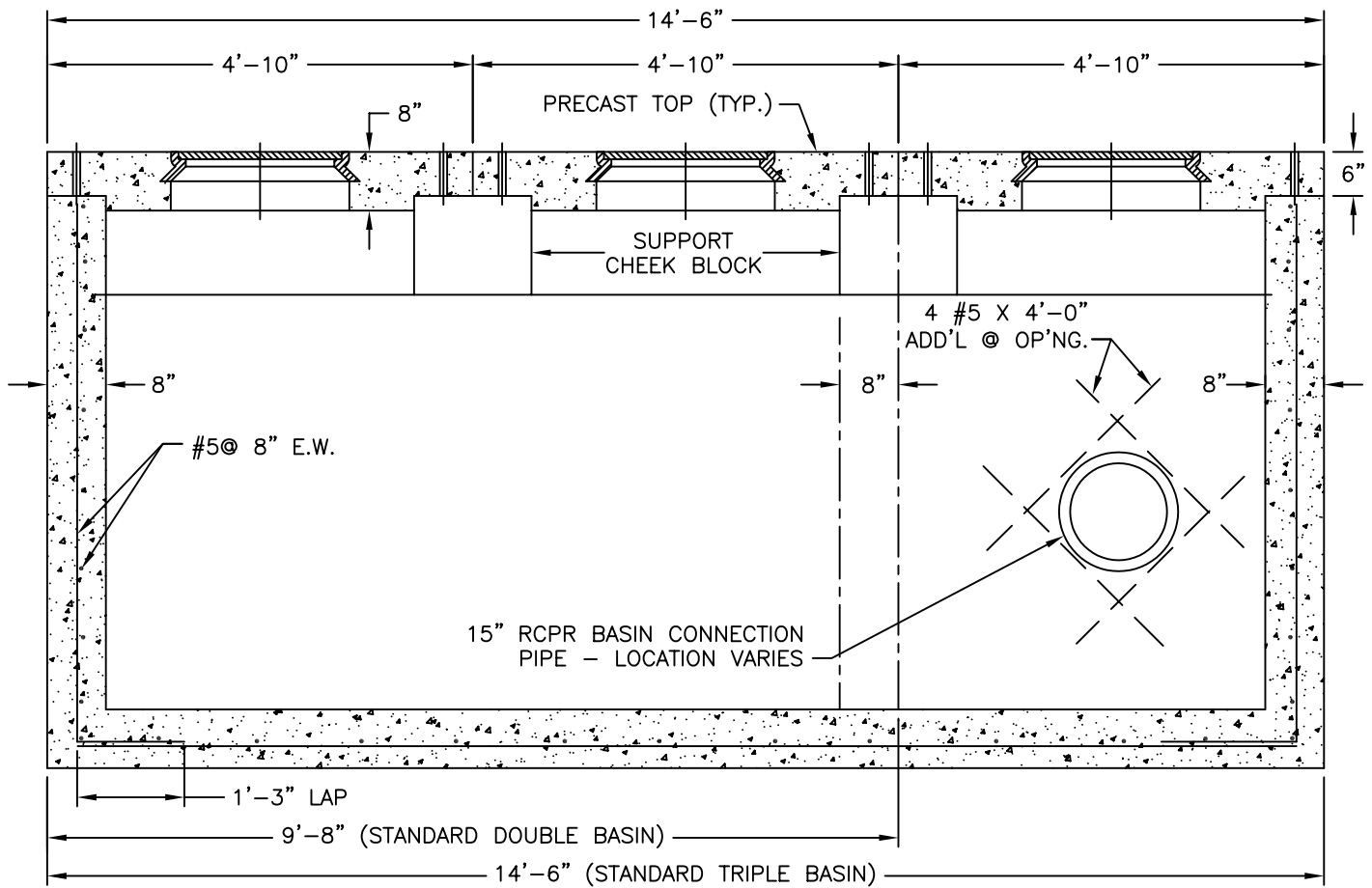

SECTION B-B

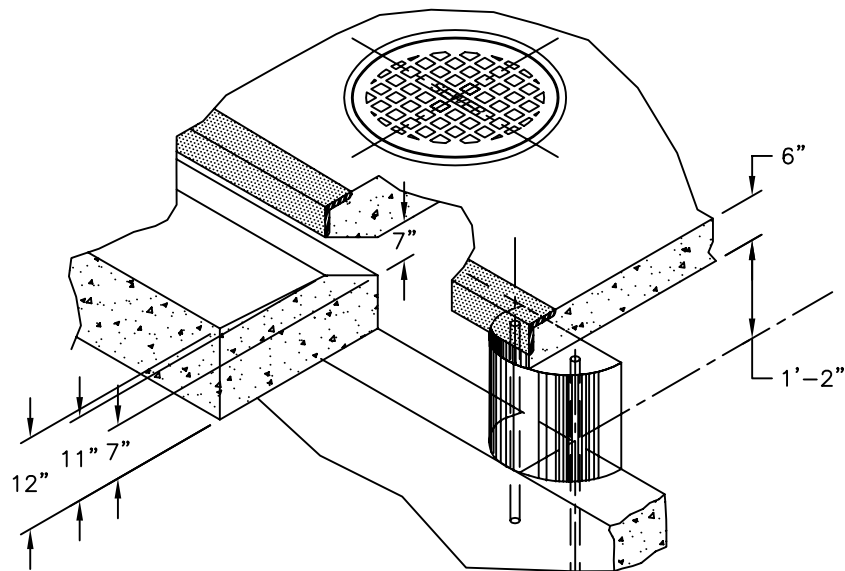

DETAIL A

APPROVED DATE: June 20, 2003

DIRECTOR, DEPARTMENT OF ENGINEERING
AND TECHNICAL SERVICES

REVISION NO.: 0
DATE: 6/20/03
PREPARED BY: OBG/BKJV
CHECKED BY: W.DARROW

STANDARD DETAIL

STANDARD DOUBLE AND
STANDARD TRIPLE BASINS

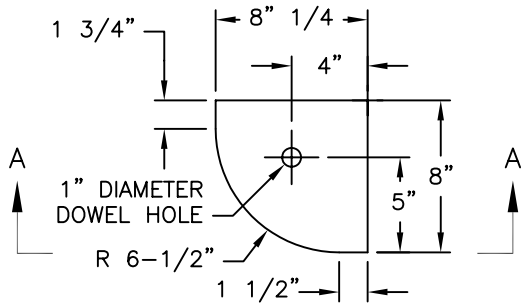

PLAN - CORNER CHEEK BLOCK

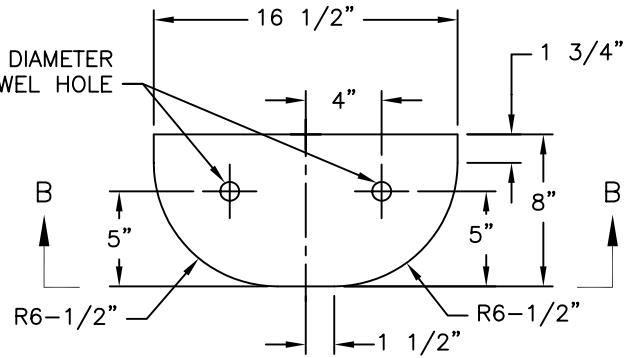

PLAN - SUPPORT CHEEK BLOCK

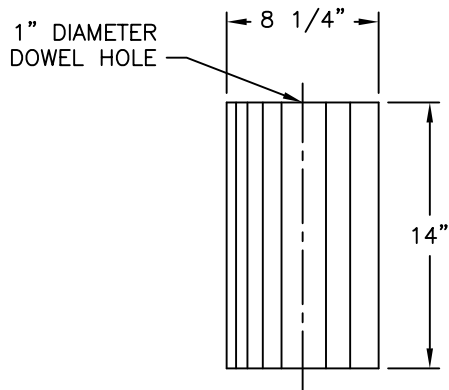

SECTION A - A

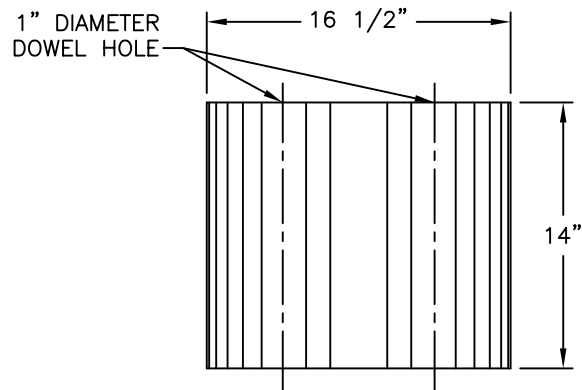

SECTION B - B

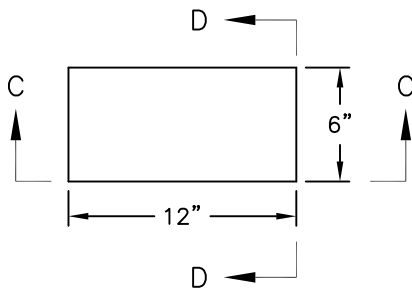

PLAN - SADDLE BLOCK

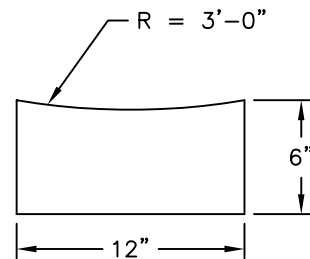

SECTION C - C

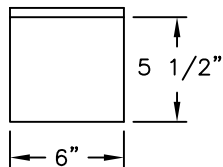

SECTION D - D

NOTES:

1. SEE SPECIFICATIONS
2. CLASS 4000 CONCRETE, AIR ENTRAINMENT, TYPE II CEMENT.

APPROVED DATE: June 20, 2003

DIRECTOR, DEPARTMENT OF ENGINEERING
AND TECHNICAL SERVICES

REVISION NO.: 0
DATE: 6/20/03
PREPARED BY: OBG/BKJV
CHECKED BY: W.DARROW

STANDARD DETAIL

DETAILS FOR CHEEK BLOCKS
AND SADDLE BLOCKS

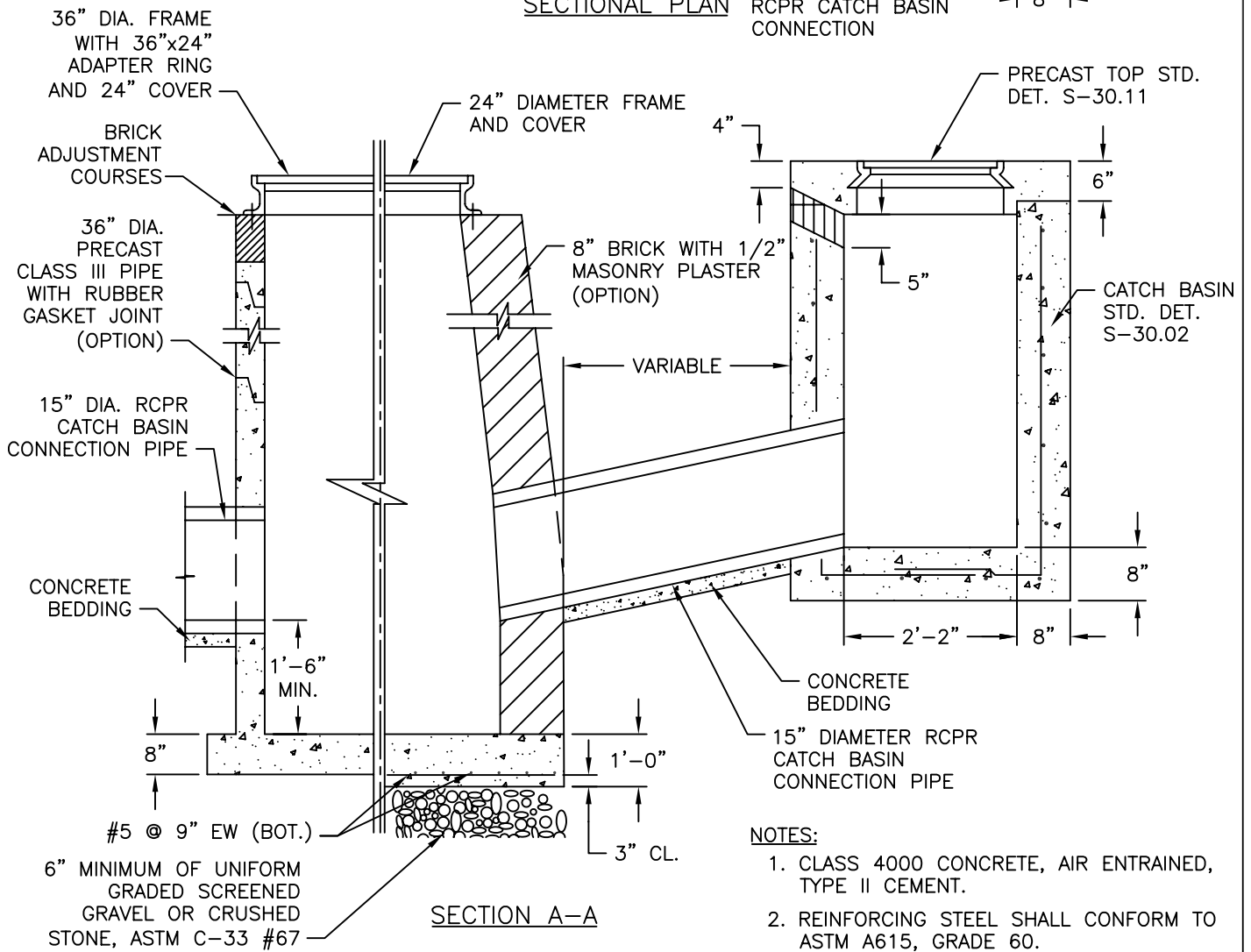
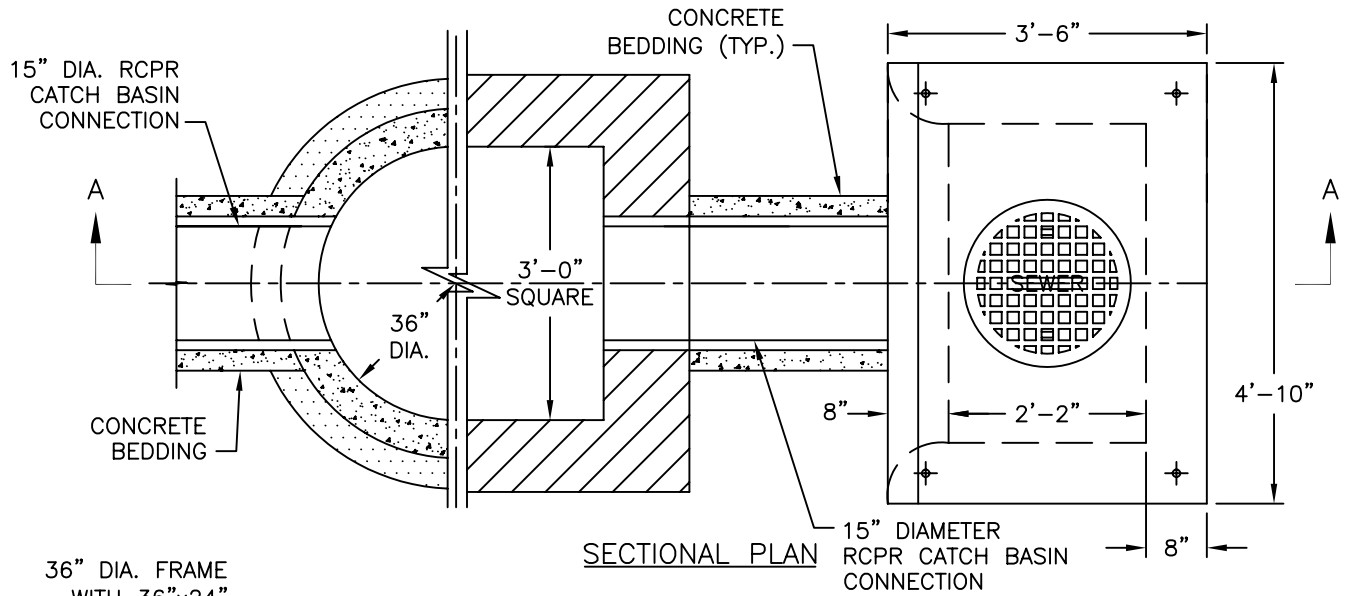

NOTES:

1. CLASS 4000 CONCRETE, AIR ENTRAINED, TYPE II CEMENT.
2. REINFORCING STEEL SHALL CONFORM TO ASTM A615, GRADE 60.

APPROVED DATE: June 20, 2003

DIRECTOR, DEPARTMENT OF ENGINEERING AND TECHNICAL SERVICES

REVISION NO.: 0
DATE: 6/20/03
PREPARED BY: OBG/BKJV
CHECKED BY: W.DARROW

STANDARD DETAIL

SHALLOW TYPE CATCH BASIN WITH CATCHMENT MANHOLE

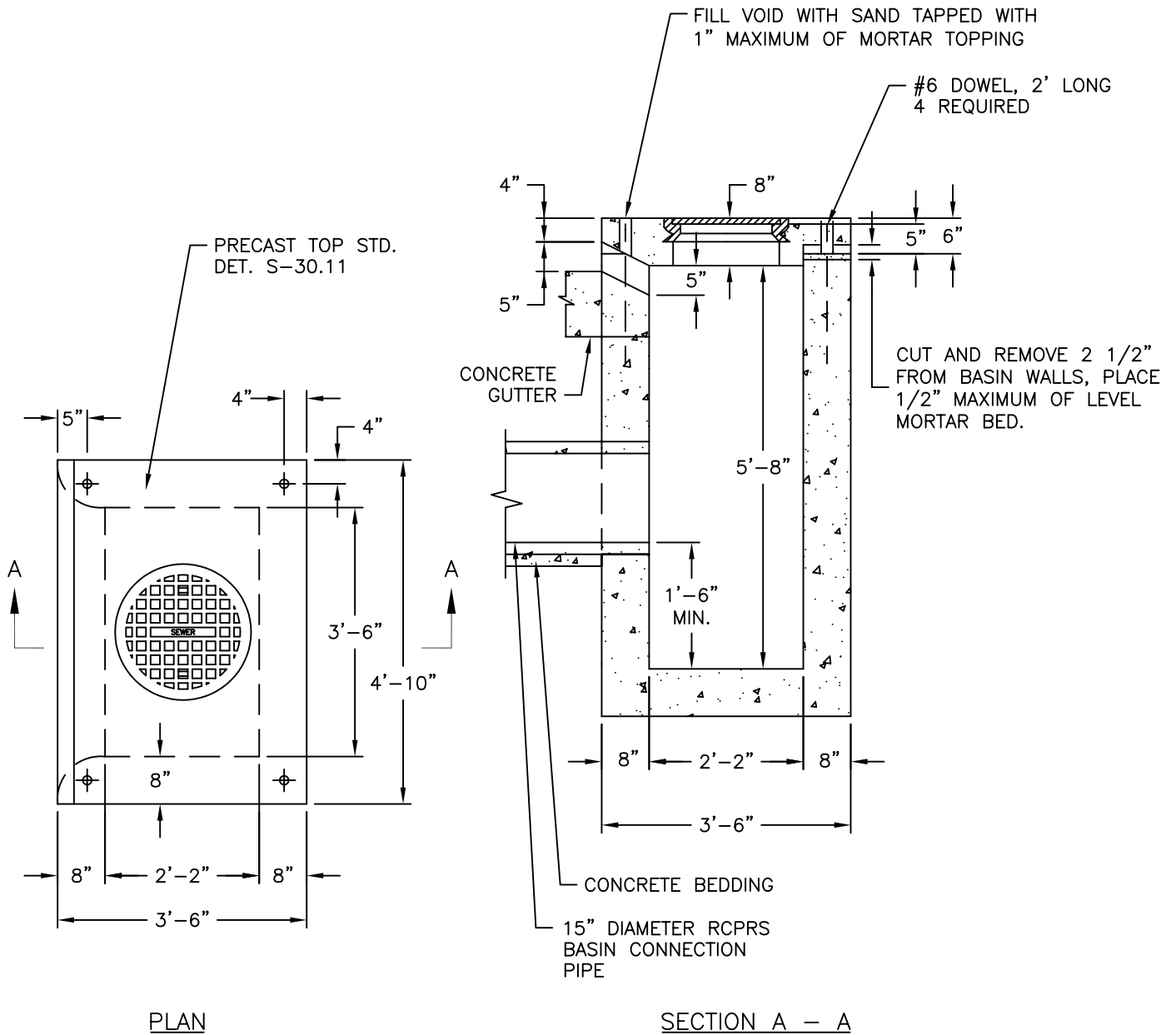

NOTE:

ALL CONCRETE TO BE CLASS 4000, AIR ENTRAINED,
TYPE II CEMENT.

APPROVED DATE: June 20, 2003

DIRECTOR, DEPARTMENT OF ENGINEERING
AND TECHNICAL SERVICES

REVISION NO.: 0
DATE: 6/20/03
PREPARED BY: OBG/BKJV
CHECKED BY: W.DARROW

STANDARD DETAIL
STANDARD CATCH BASIN MODIFICATION FOR
PLACEMENT OF 8" PRECAST STANDARD CATCH
BASIN TOP

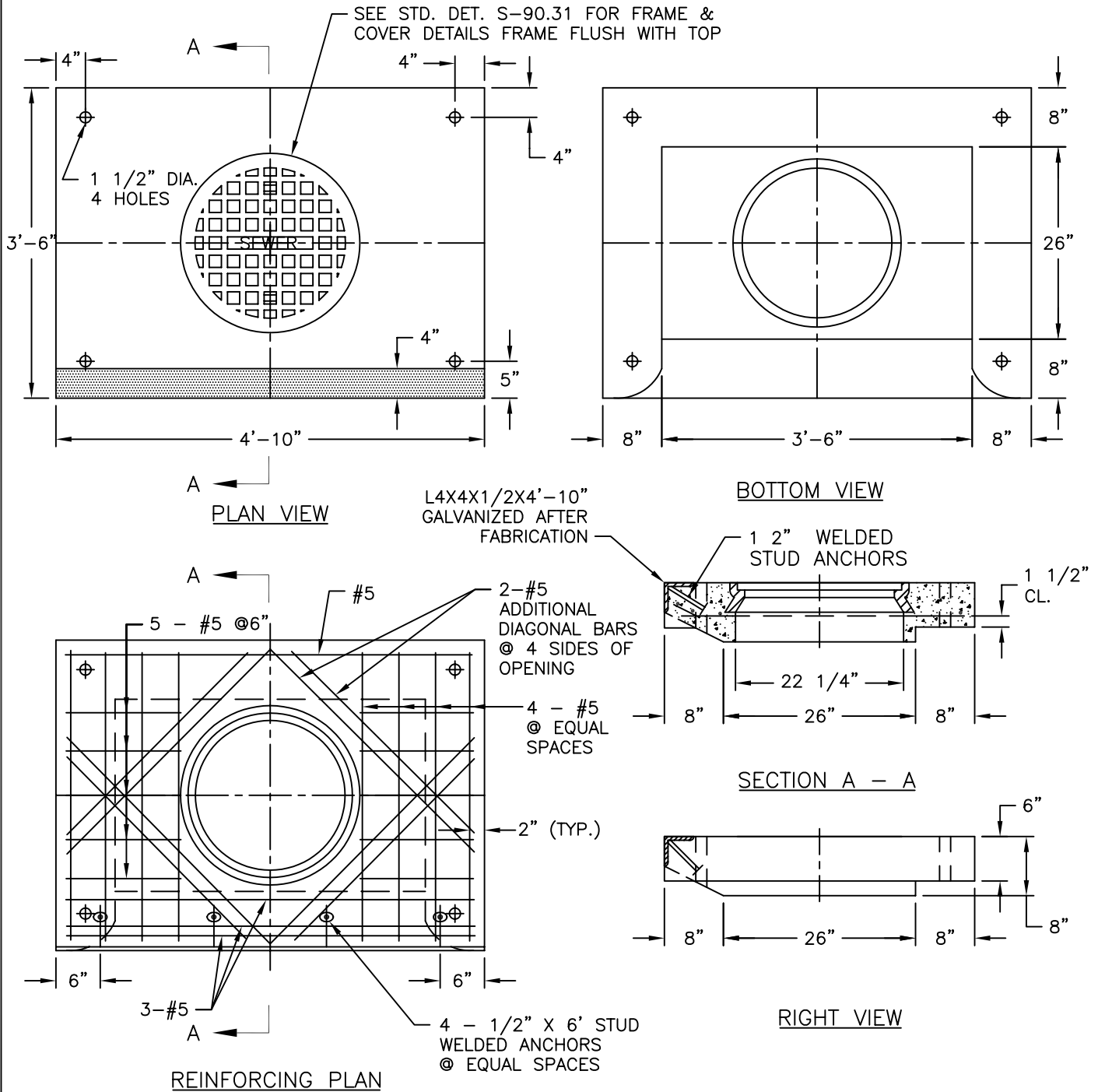

NOTES:

1. SEE SPECIFICATIONS
2. CLASS 4000 CONCRETE, AIR ENTRAINED, TYPE II CEMENT.
3. REINFORCING STEEL, ASTM A615, GRADE 60, 1 1/2" CLEAR COVER UNLESS NOTED
4. STEEL ANGLE PER ASTM A36, GALVANIZED PER ASTM A123
5. STUD ANCHORS SHALL BE LOW CARBON STEEL, ASTM A108, TYPE H4L NELSON HEADED ANCHORS WITH FLUXED ENDS, BY NELSON STUD WELDING CO. OR APPROVED EQUAL

APPROVED DATE: June 20, 2003

DIRECTOR, DEPARTMENT OF ENGINEERING
AND TECHNICAL SERVICES

REVISION NO.: 0
DATE: 6/20/03
PREPARED BY: OBG/BKJV
CHECKED BY: W.DARROW

STANDARD DETAIL

8" PRECAST STANDARD
CATCH BASIN TOP

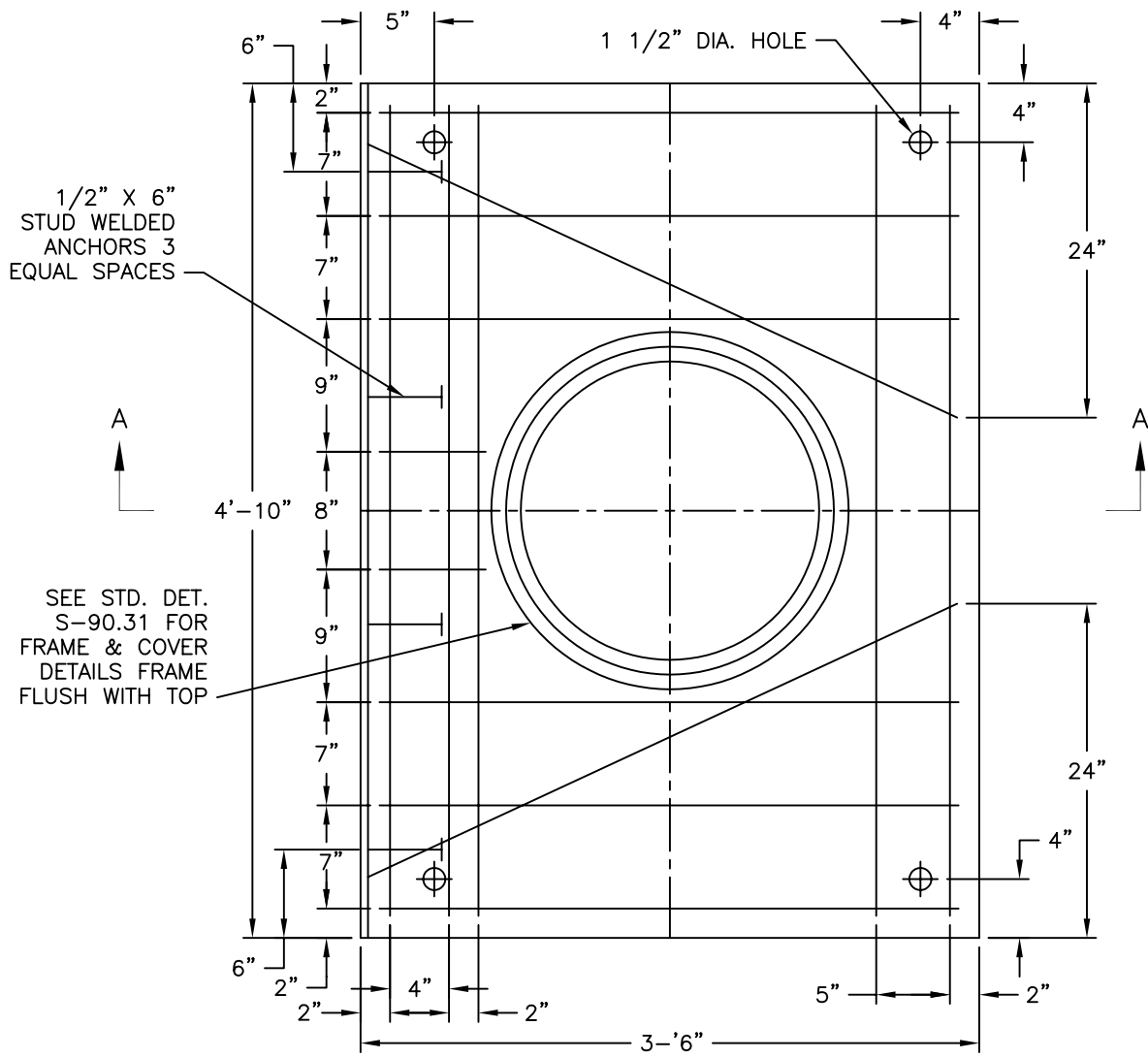

1/2" X 6"
STUD WELDED
ANCHORS 3
EQUAL SPACES

SEE STD. DET.
S-90.31 FOR
FRAME & COVER
DETAILS FRAME
FLUSH WITH TOP

SECTIONAL PLAN

L4 X 4 1/2 X
4'-10" GALVANIZED
AFTER FABRICATION

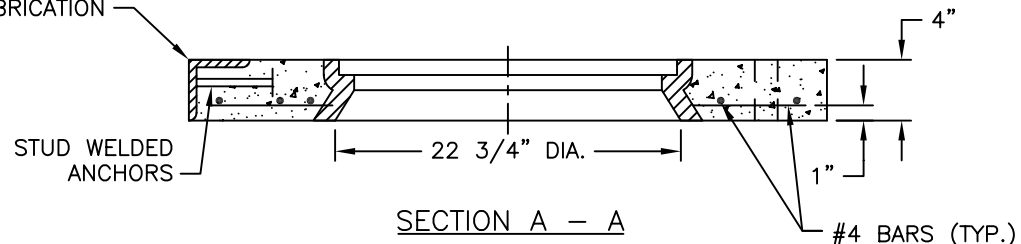

SECTION A - A

NOTES:

1. CLASS 4000 CONCRETE, AIR ENTRAINED, TYPE II CEMENT
2. REINFORCING STEEL, ASTM A615, GRADE 60
3. STEEL ANGLE PER ASTM A36, GALVANIZED PER ASTM A123
4. STUD ANCHORS SHALL BE LOW CARBON STEEL, ASTM A108, TYPE H4L NELSON HEADED ANCHORS WITH FLUXED ENDS, BY NELSON STUD WELDING CO. OR APPROVED EQUAL

APPROVED DATE: June 20, 2003

DIRECTOR, DEPARTMENT OF ENGINEERING
AND TECHNICAL SERVICES

REVISION NO.: 0
DATE: 6/20/03
PREPARED BY: OBG/BKJV
CHECKED BY: W.DARROW

STANDARD DETAIL
4" PRECAST STANDARD CATCH BASIN TOP
(FOR REPLACEMENT ONLY)

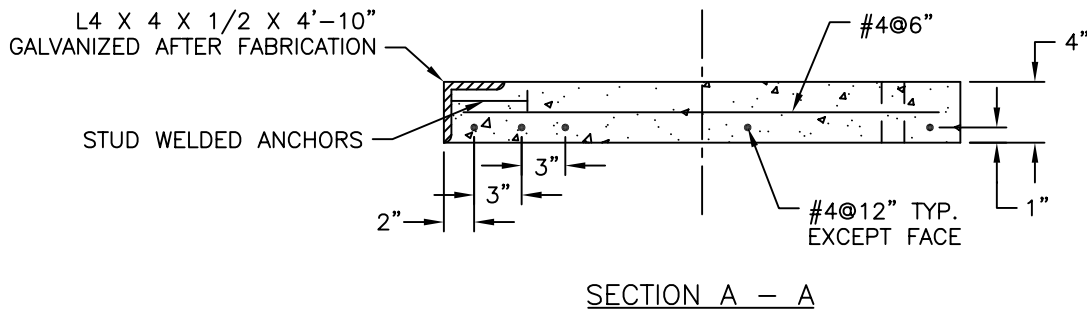
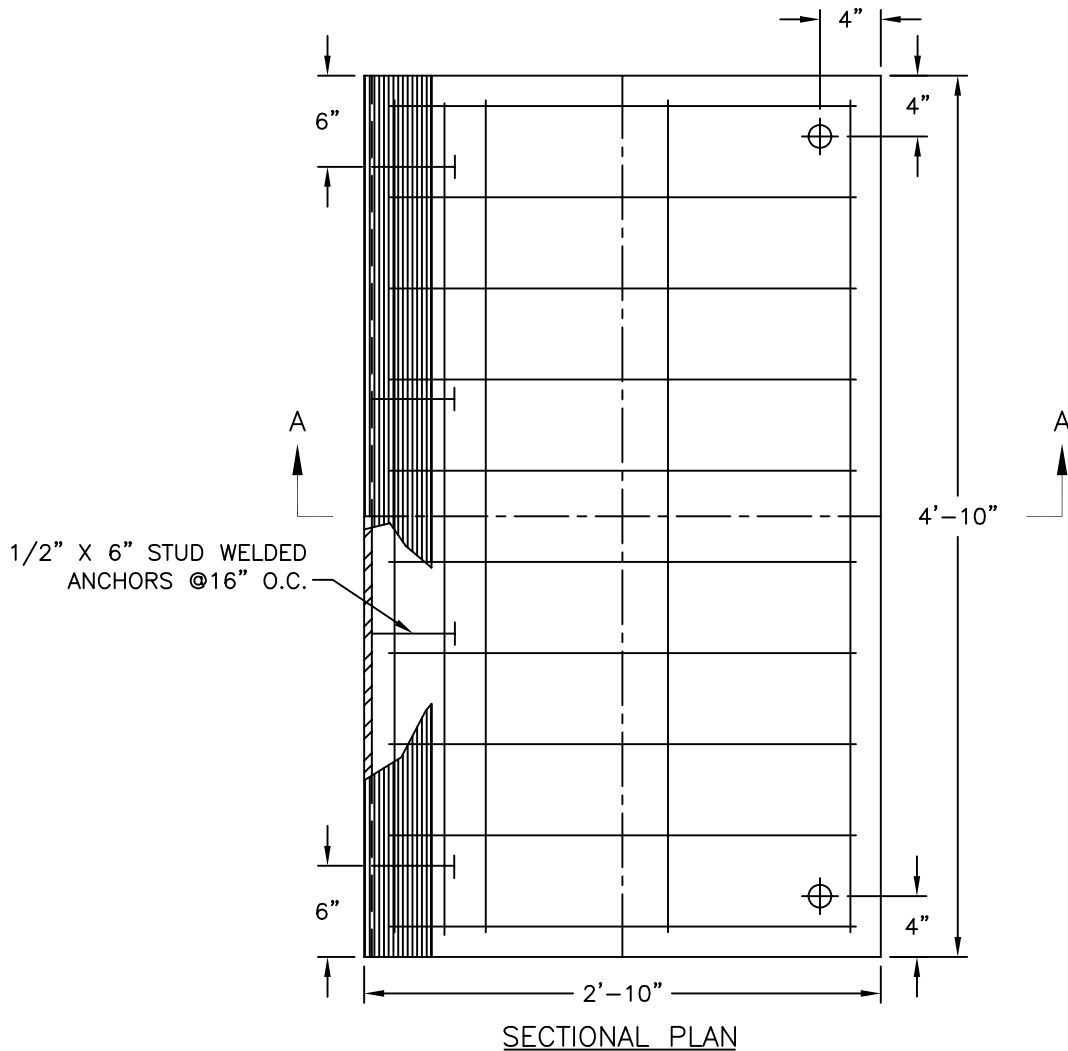

NOTES:

1. CLASS 4000 CONCRETE, AIR ENTRAINED, TYPE II CEMENT
2. REINFORCING STEEL, ASTM A615, GRADE 60
3. STEEL ANGLE PER ASTM A36, GALVANIZED PER ASTM A123
4. STUD ANCHORS SHALL BE LOW CARBON STEEL, ASTM A108, TYPE H4L NELSON HEADED ANCHORS WITH FLUXED ENDS, BY NELSON STUD WELDING CO. OR APPROVED EQUAL

APPROVED DATE: June 20, 2003

DIRECTOR, DEPARTMENT OF ENGINEERING
 AND TECHNICAL SERVICES

REVISION NO.: 0
 DATE: 6/20/03
 PREPARED BY: OBG/BKJV
 CHECKED BY: W.DARROW

STANDARD DETAIL
 4" PRECAST CATCH BASIN
 ELONGATION TOP
 (FOR REPLACEMENT ONLY)

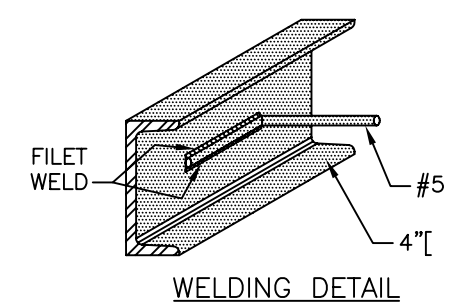
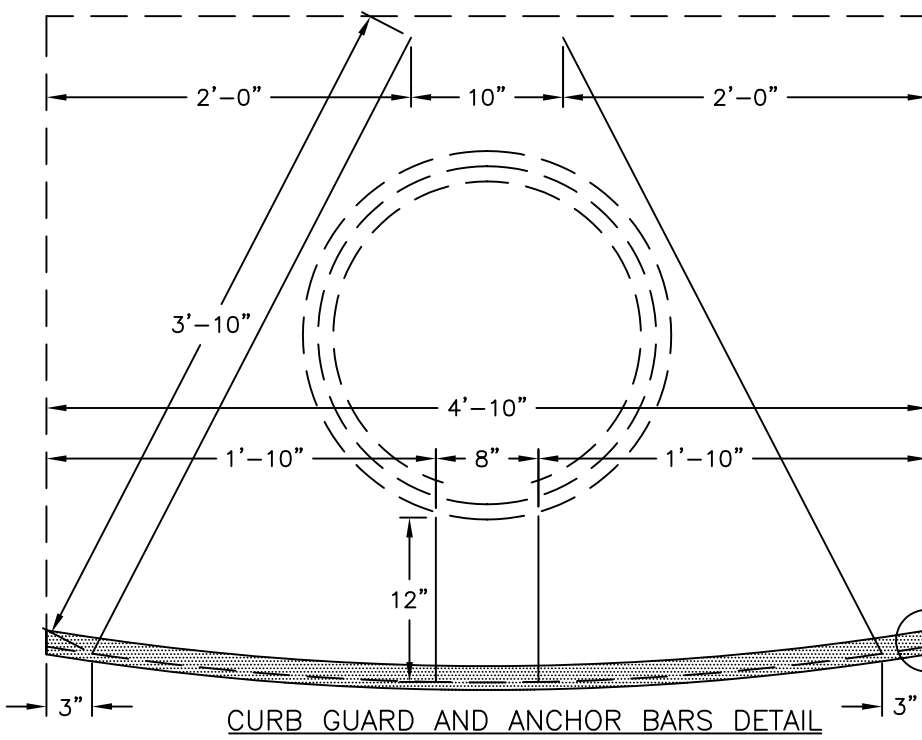
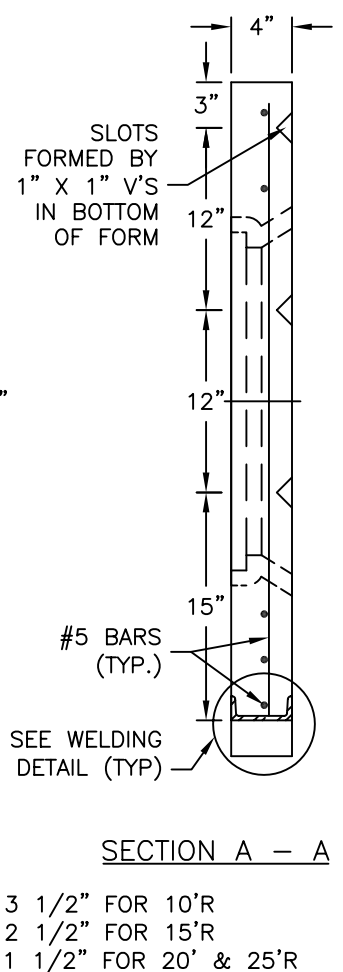
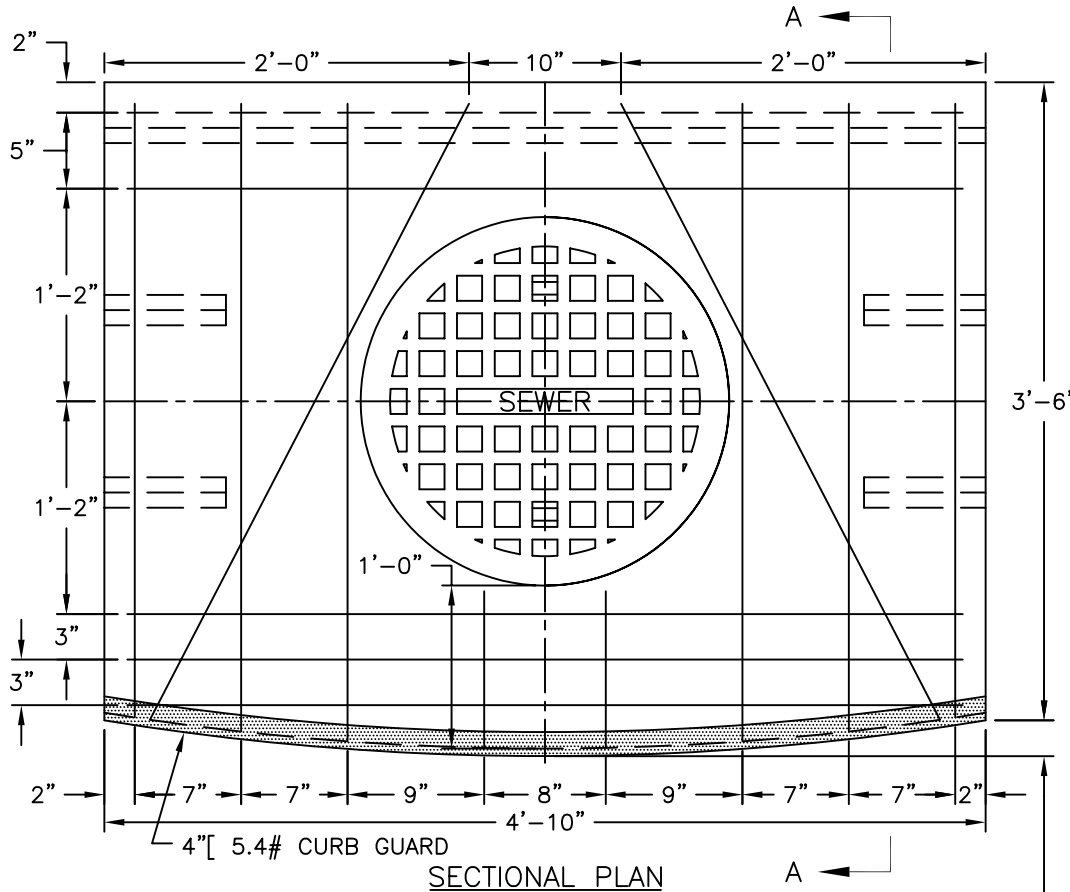

- NOTES:
1. ALL CONCRETE TO BE CLASS 4000, AIR ENTRAINED
 2. REINFORCING STEEL ASTM A615, GRADE 60
 3. STEEL CHANNEL PER ASTM A36, GALVANIZED PER ASTM A123
- SEE WELDING DETAIL (TYP.)

APPROVED DATE: June 20, 2003

DIRECTOR, DEPARTMENT OF ENGINEERING
AND TECHNICAL SERVICES

REVISION NO.: 0

DATE: 6/20/03

PREPARED BY: OBG/BKJV

CHECKED BY: W.DARROW

STANDARD DETAIL

PRECAST CORNER CATCH BASIN TOP
(FOR REPLACEMENT ONLY)

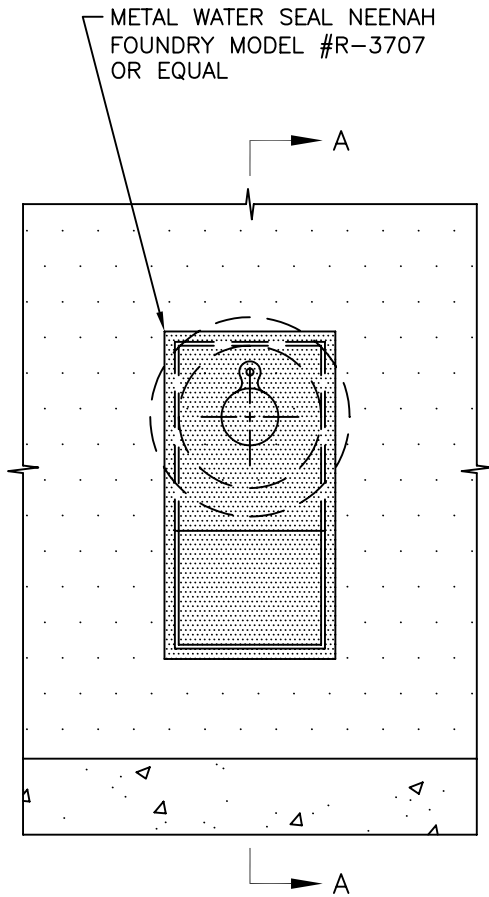

FRONT ELEVATION

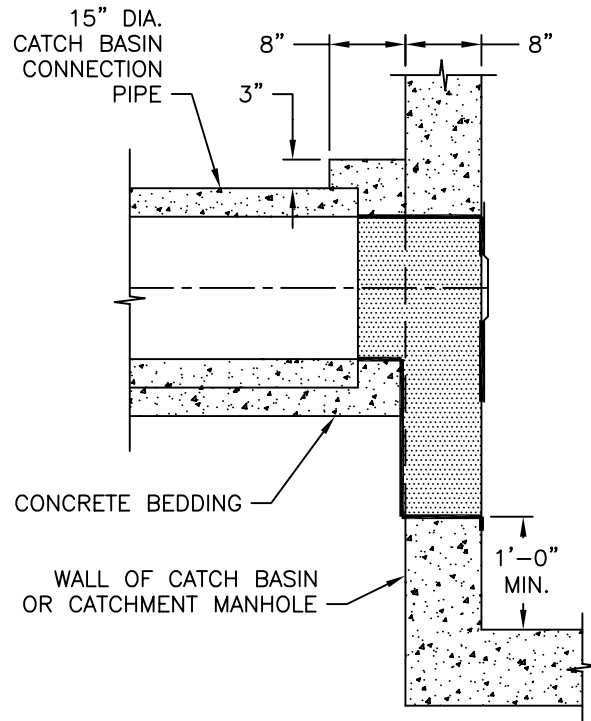

SECTION A-A

NOTES:

1. GRAY IRON CASTINGS PER ASTM A-48, CLASS 30A.
2. ALL MACHINE FINISH TO BE A.S.A. SPECIFICATION, ROUGHNESS SYMBOL 250, TOLERANCE $-0" +1/16"$.
3. WHEN THE CATCH BASIN CONNECTION PIPE IS NOT PERPENDICULAR TO THE CATCH BASIN WALL, THE WALL SHALL BE MODIFIED TO INSTALL WATER SEAL ON SAME ALIGNMENT AS THE CATCH BASIN PIPE, SEE SECTIONAL PLAN, SHEET 2 OF 2 FOR TYPICAL DETAIL.

APPROVED DATE: June 20, 2003

DIRECTOR, DEPARTMENT OF ENGINEERING
 AND TECHNICAL SERVICES

REVISION NO.: 0
 DATE: 6/20/03
 PREPARED BY: OBG/BKJV
 CHECKED BY: W.DARROW

STANDARD DETAIL
 WATER SEAL FOR 15" DIAMETER
 CATCH BASIN CONNECTION
 (COMBINED AREA ONLY)

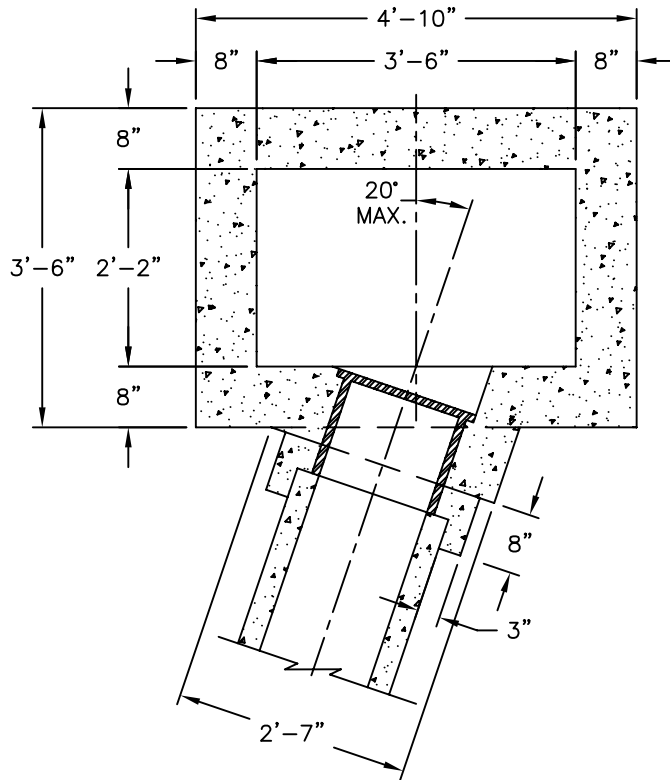

SECTIONAL PLAN

APPROVED DATE: June 20, 2003

DIRECTOR, DEPARTMENT OF ENGINEERING
 AND TECHNICAL SERVICES

REVISION NO.: 0
 DATE: 6/20/03
 PREPARED BY: OBG/BKJV
 CHECKED BY: W.DARROW

STANDARD DETAIL

TYPICAL FOR NON-PERPENDICULAR
 CATCH BASIN CONNECTION PIPE

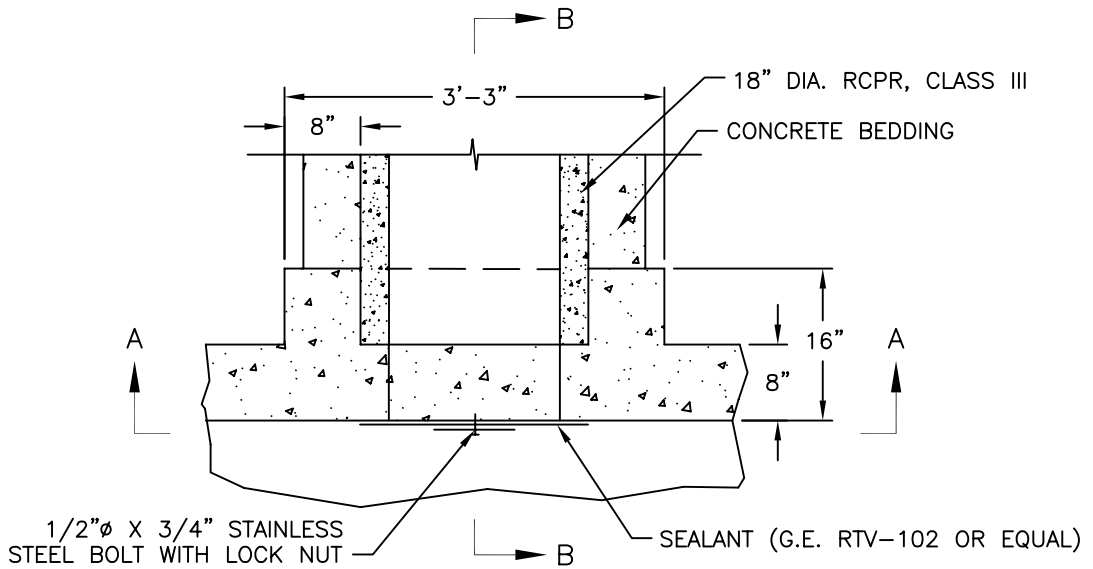

SECTIONAL PLAN

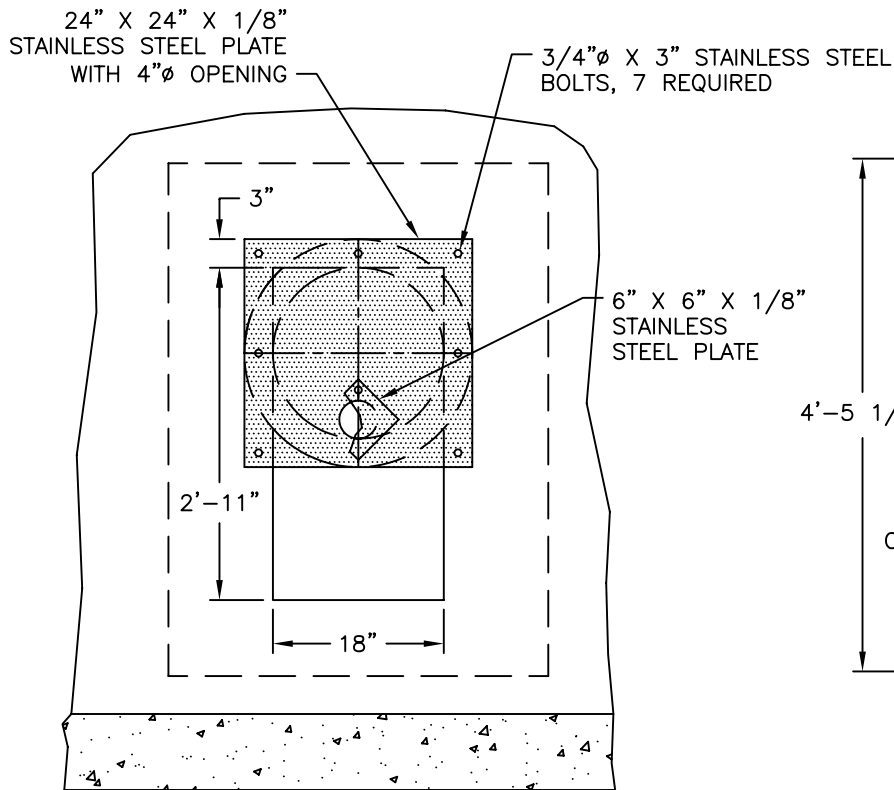

SECTION A-A

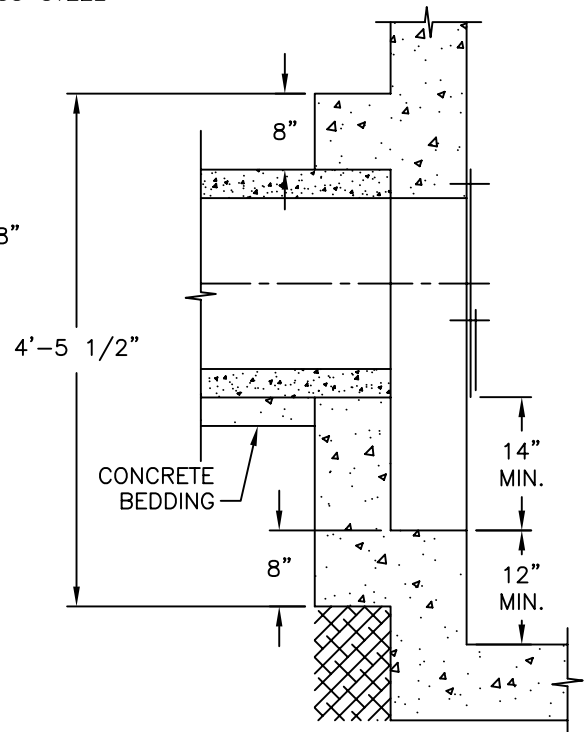

SECTION B-B

APPROVED DATE: June 20, 2003

DIRECTOR, DEPARTMENT OF ENGINEERING
AND TECHNICAL SERVICES

REVISION NO.: 0
DATE: 6/20/03
PREPARED BY: OBG/BKJV
CHECKED BY: W.DARROW

STANDARD DETAIL
WATER SEAL FOR 18" DIAMETER
CATCH BASIN CONNECTION
(COMBINED SYSTEM ONLY)

C.I. FRAME AND GRATE
NEENAH FOUNDRY R-3350

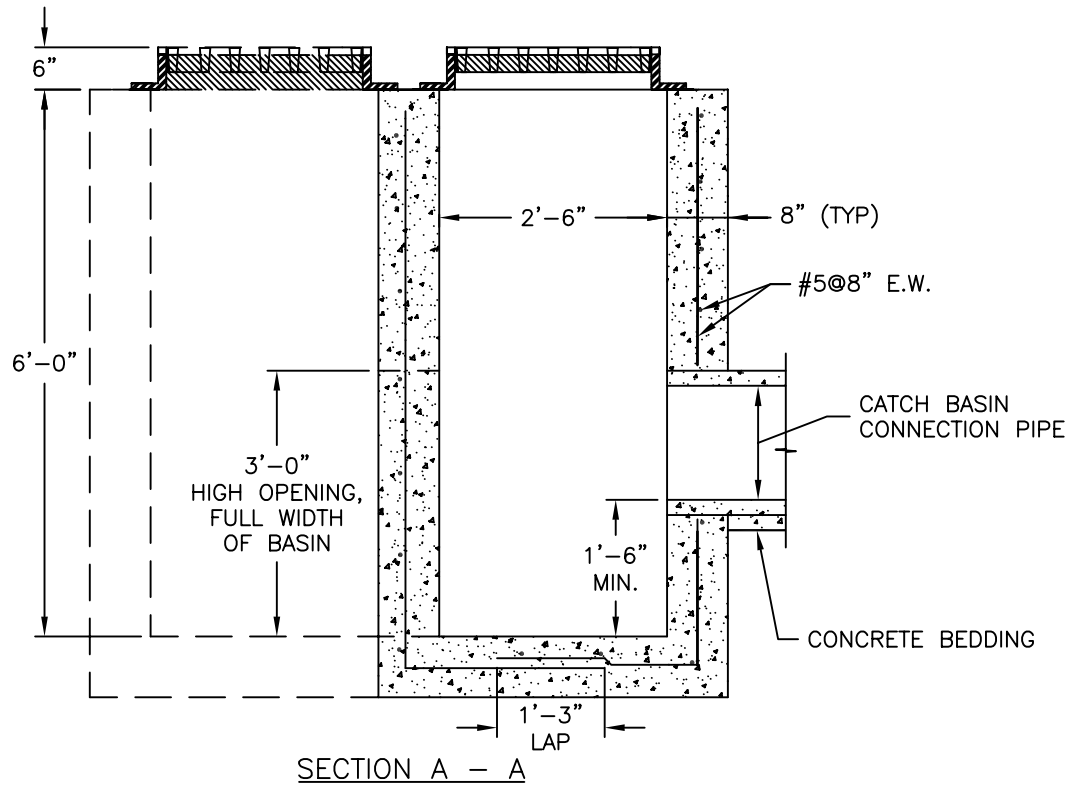
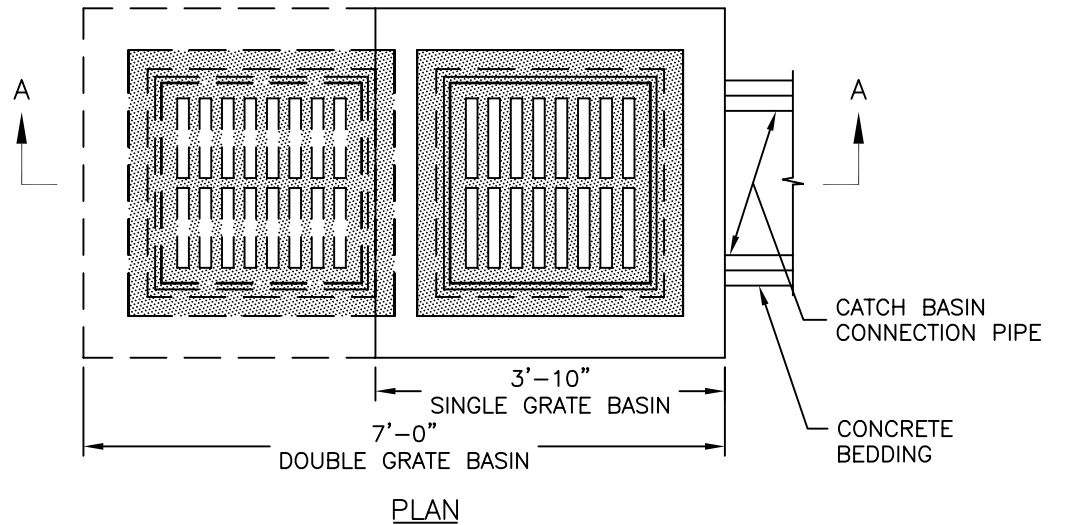

NOTES:

1. GRAY IRON CASTING PER ASTM A-48, CLASS 30A.
2. ALL MACHINE FINISH TO BE A.S.A. SPECIFICATION, ROUGHNESS SYMBOL 250, TOLERANCE $-0 + 1/16"$.
3. ALL CONCRETE TO BE CLASS 4000, AIR ENTRAINED TYPE II CEMENT.
4. BASIN TO BE USED IN UNPAVED AREAS ONLY.
5. REINFORCING SHALL BE CENTERED IN WALL AND BASE AND SHALL CONFORM TO ASTM A615 GRADE 60.

APPROVED DATE: June 20, 2003

DIRECTOR, DEPARTMENT OF ENGINEERING
AND TECHNICAL SERVICES

REVISION NO.: 0
DATE: 6/20/03
PREPARED BY: OBG/BKJV
CHECKED BY: W.DARROW

STANDARD DETAIL

FIELD INLET
GRATE TYPE CATCH BASIN

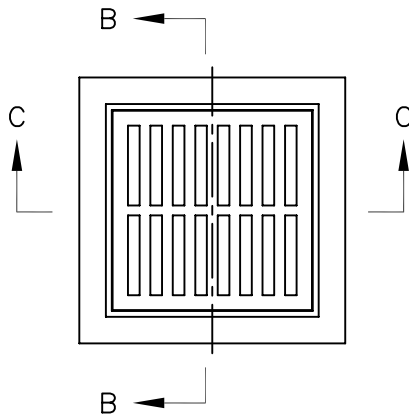

PLAN

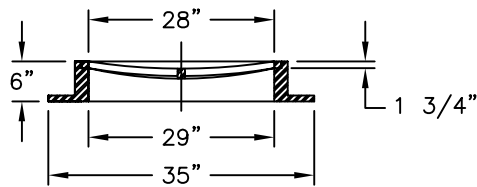

SECTION B - B

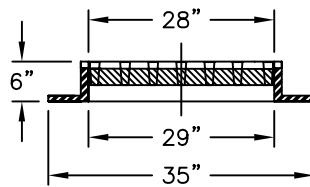

SECTION C - C

APPROVED DATE: June 20, 2003

DIRECTOR, DEPARTMENT OF ENGINEERING
AND TECHNICAL SERVICES

REVISION NO.: 0
DATE: 6/20/03
PREPARED BY: OBG/BKJV
CHECKED BY: W.DARROW

STANDARD DETAIL
FIELD INLET
GRATE TYPE CATCH BASIN

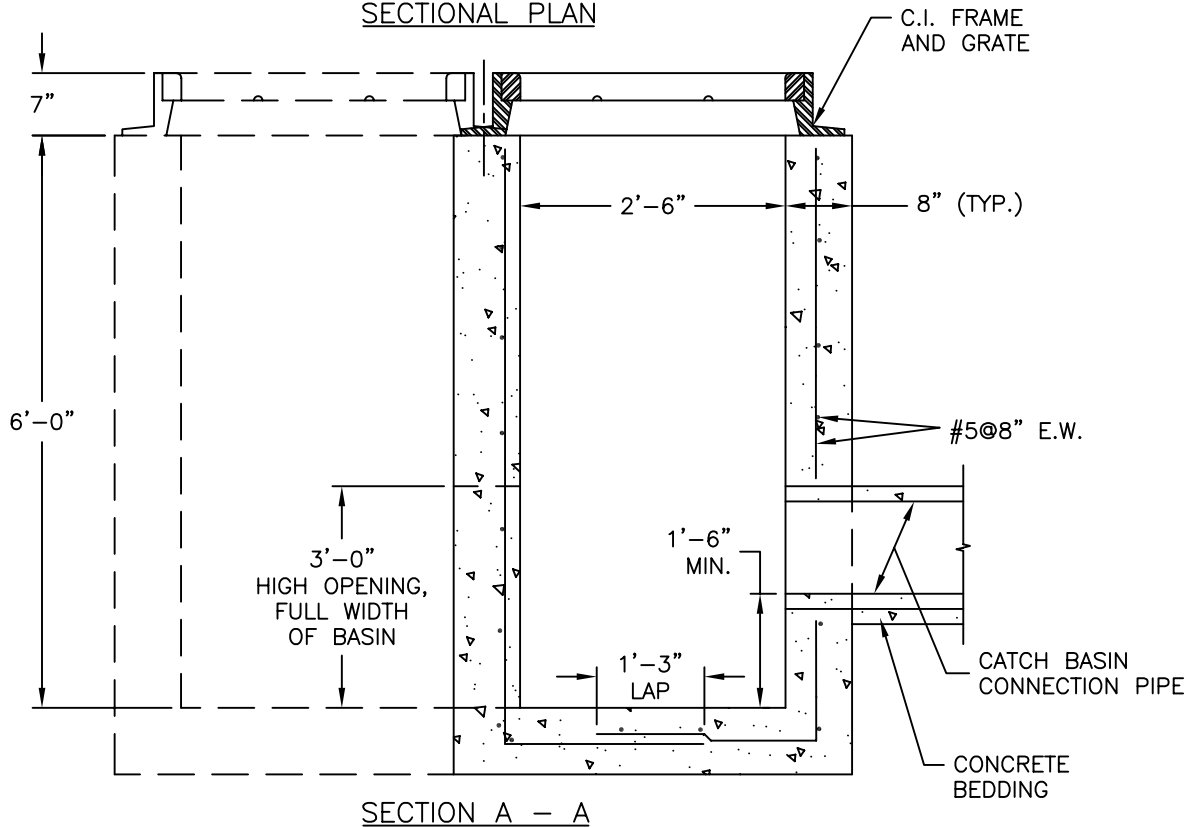
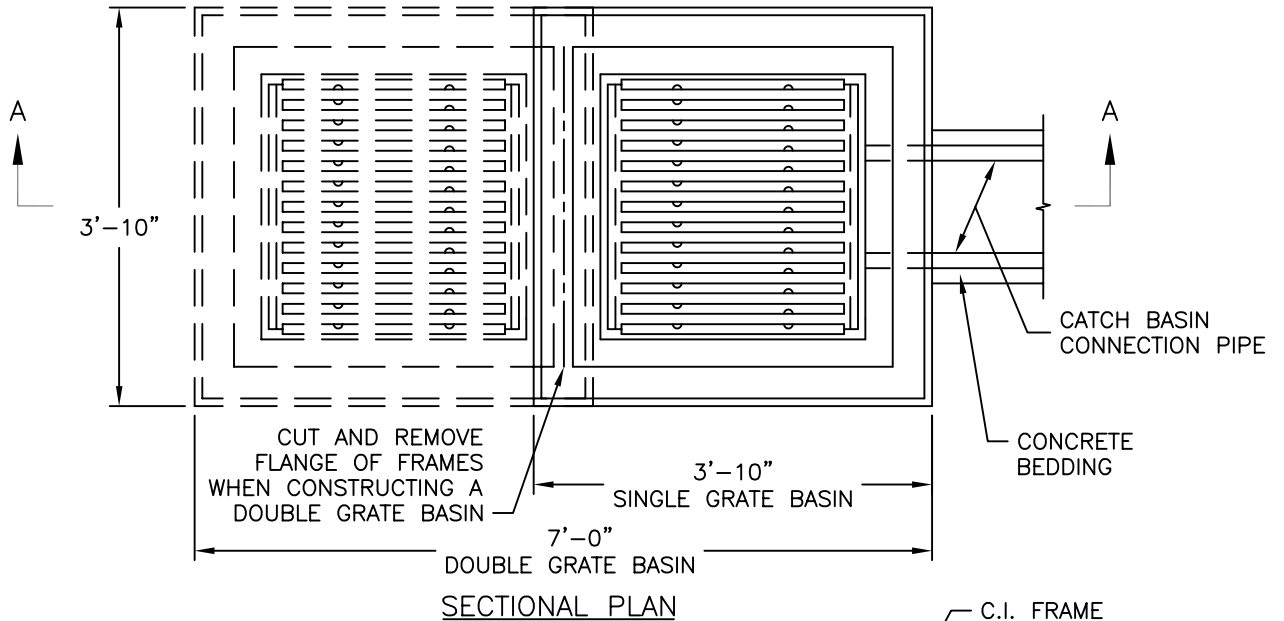

NOTES:

1. GRAY IRON CASTINGS PER ASTM A-48, CLASS 30A.
2. ALL MACHINE FINISH TO BE A.S.A. SPECIFICATION, ROUGHNESS SYMBOL 250, TOLERANCE - 0 + 1/16".
3. ALL CONCRETE TO BE CLASS 4000, AIR ENTRAINED, TYPE II CEMENT.
4. REINFORCING SHALL BE CENTERED IN WALL AND BASE AND SHALL CONFORM TO ASTM A615 GRADE 60.

APPROVED DATE: June 20, 2003

DIRECTOR, DEPARTMENT OF ENGINEERING
AND TECHNICAL SERVICES

REVISION NO.: 0
DATE: 6/20/03
PREPARED BY: OBG/BKJV
CHECKED BY: W.DARROW

STANDARD DETAIL

GRATE TYPE CATCH
BASIN WITH SAFETY GRATE

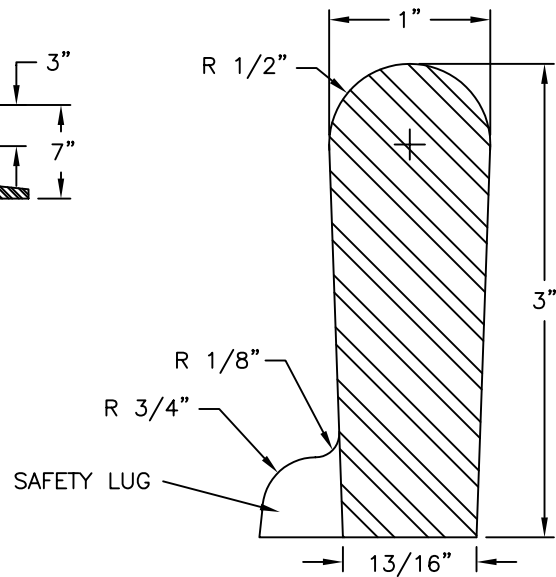
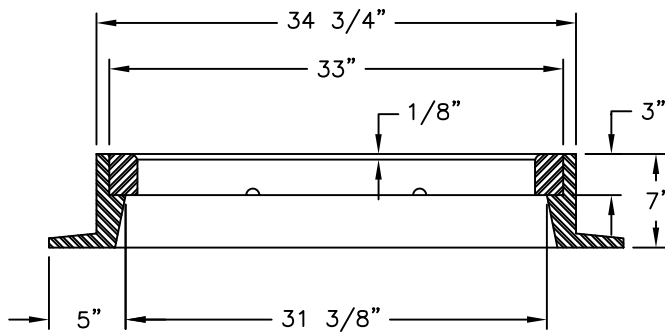
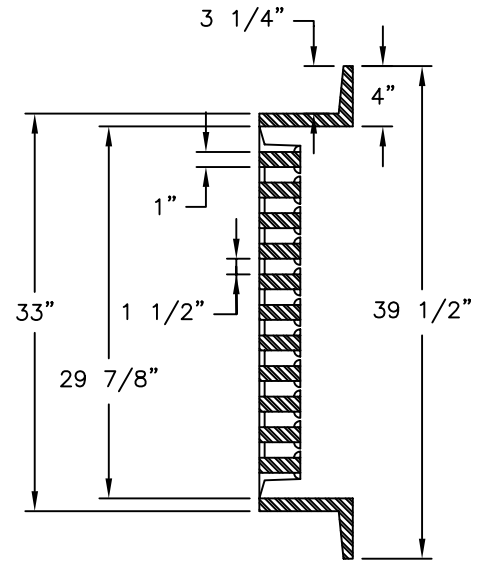
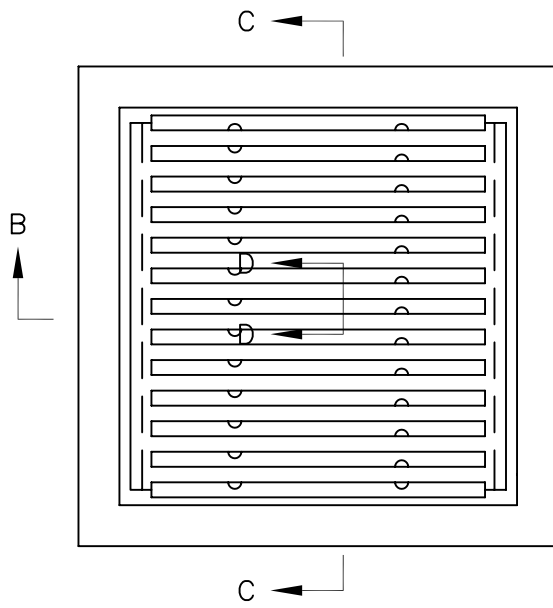

APPROVED DATE: June 20, 2003

DIRECTOR, DEPARTMENT OF ENGINEERING
AND TECHNICAL SERVICES

REVISION NO.: 0
DATE: 6/20/03
PREPARED BY: OBG/BKJV
CHECKED BY: W.DARROW

STANDARD DETAIL
GRATE TYPE CATCH
BASIN WITH SAFETY GRATE

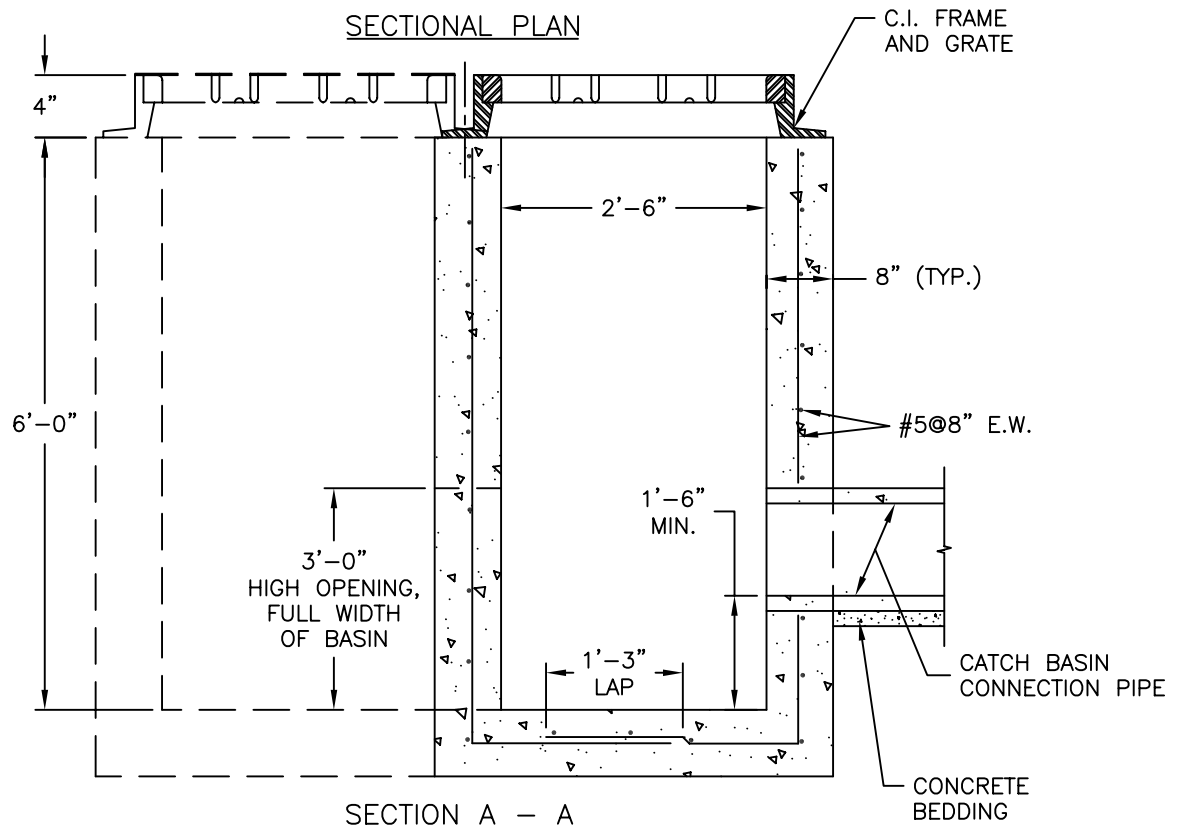
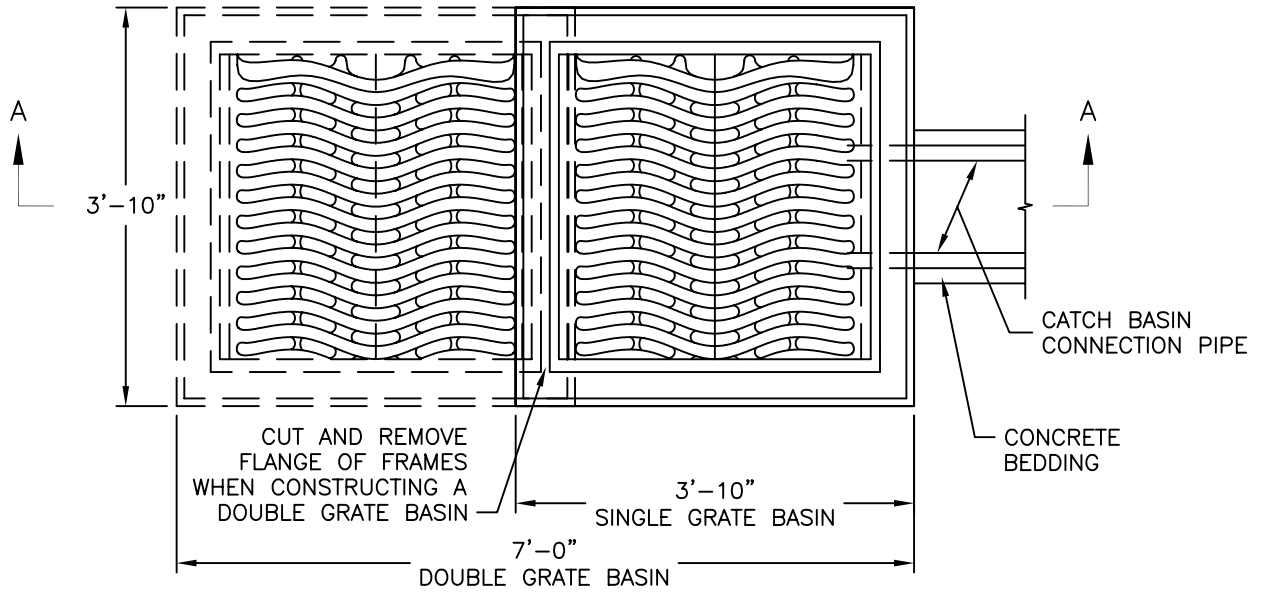

NOTES:

1. GRAY IRON CASTINGS PER ASTM A-48, CLASS 30A.
2. ALL MACHINE FINISH TO BE A.S.A. SPECIFICATION, ROUGHNESS SYMBOL 250, TOLERANCE - 0 + 1/16".
3. ALL CONCRETE TO BE CLASS 4000, AIR ENTRAINED, TYPE II CEMENT.
4. REINFORCING SHALL BE CENTERED IN WALL AND BASE AND SHALL CONFORM TO ASTM A615 GRADE 60.

APPROVED DATE: June 20, 2003

DIRECTOR, DEPARTMENT OF ENGINEERING
AND TECHNICAL SERVICES

REVISION NO.: 0
DATE: 6/20/03
PREPARED BY: OBG/BKJV
CHECKED BY: W.DARROW

STANDARD DETAIL

GRATE TYPE CATCH
BASIN WITH SERPENTINE GRATE

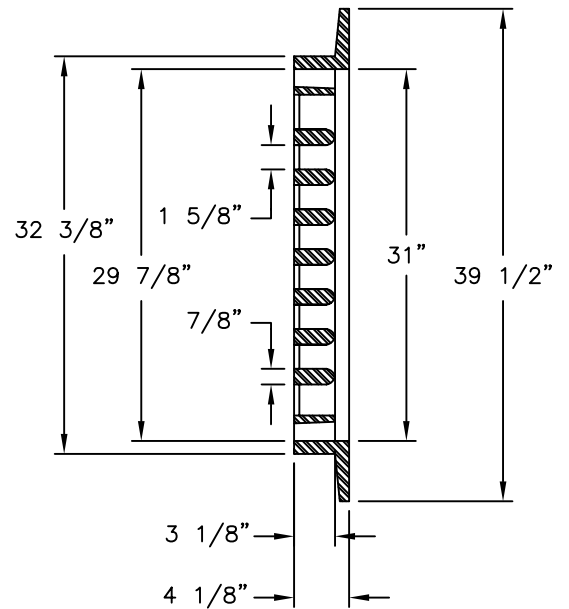
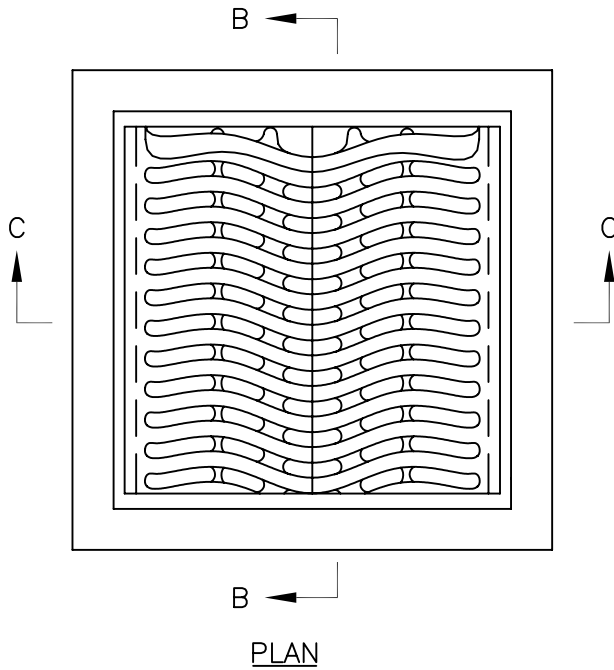

SECTION B-B

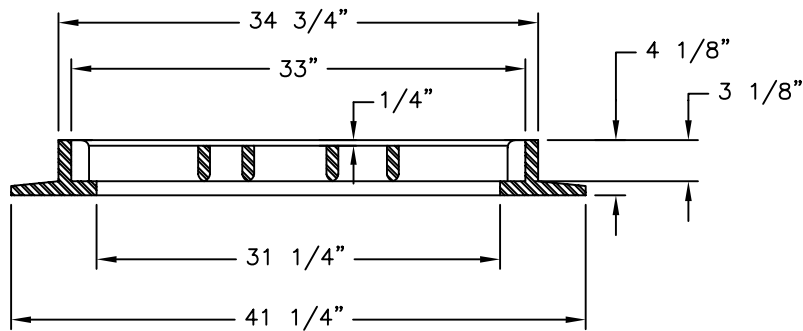

SECTION C-C

APPROVED DATE: June 20, 2003

DIRECTOR, DEPARTMENT OF ENGINEERING
AND TECHNICAL SERVICES

REVISION NO.: 0
DATE: 6/20/03
PREPARED BY: OBG/BKJV
CHECKED BY: W.DARROW

STANDARD DETAIL

GRATE TYPE CATCH
BASIN WITH SERPENTINE GRATE

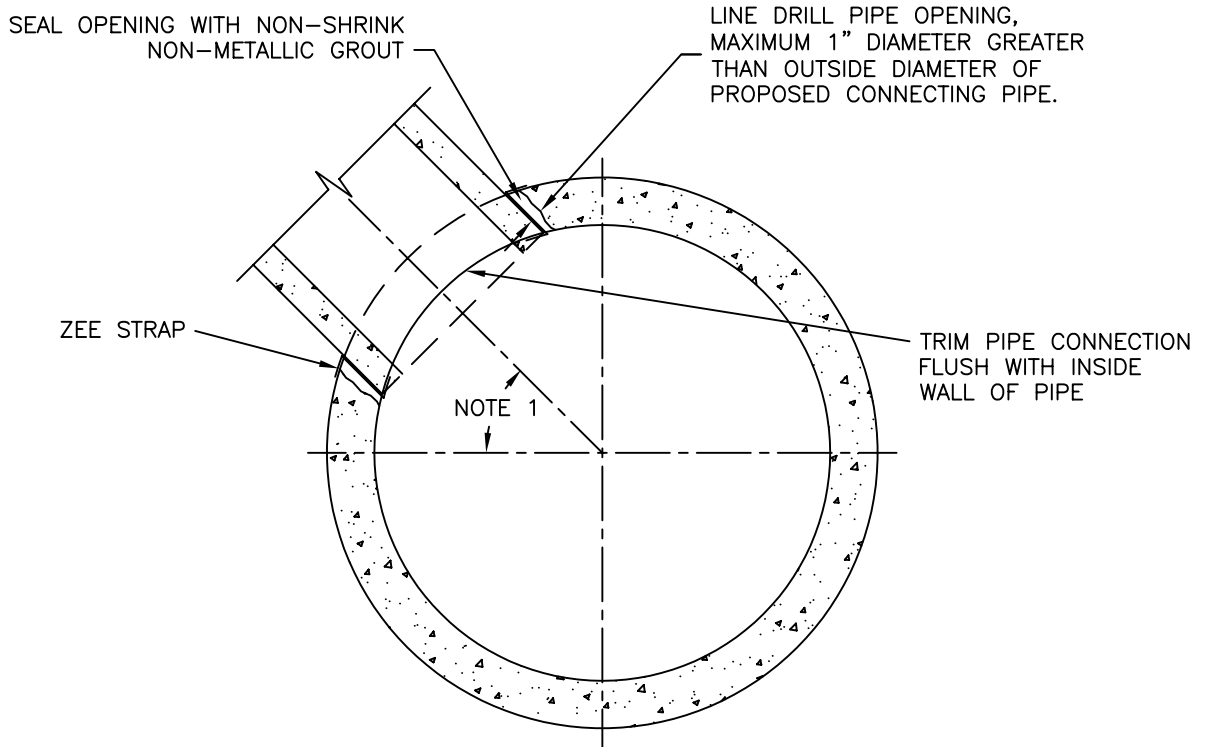

SECTIONAL CONNECTION DETAIL

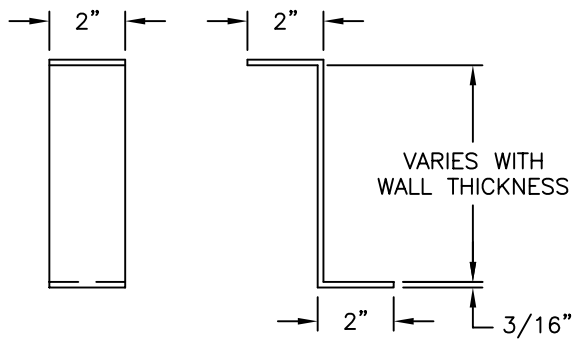

ZEE STRAP DETAIL

NOTE:

1. CONNECTIONS AT AN ANGLE GREATER THAN 45° FROM THE HORIZONTAL WILL ONLY BE PERMITTED WHEN SPECIFICALLY APPROVED BY WASA, AND MAY REQUIRE ADDITIONAL OR DIFFERENT PIPE RESTRAINT THAN ZEE STRAPS.

APPROVED DATE: June 20, 2003

DIRECTOR, DEPARTMENT OF ENGINEERING
AND TECHNICAL SERVICES

REVISION NO.: 0
DATE: 6/20/03
PREPARED BY: OBG/BKJV
CHECKED BY: W.DARROW

STANDARD DETAIL
CONNECTIONS TO SEWERS
LARGER THAN 36" I.D.
UTILIZING ZEE STRAPS

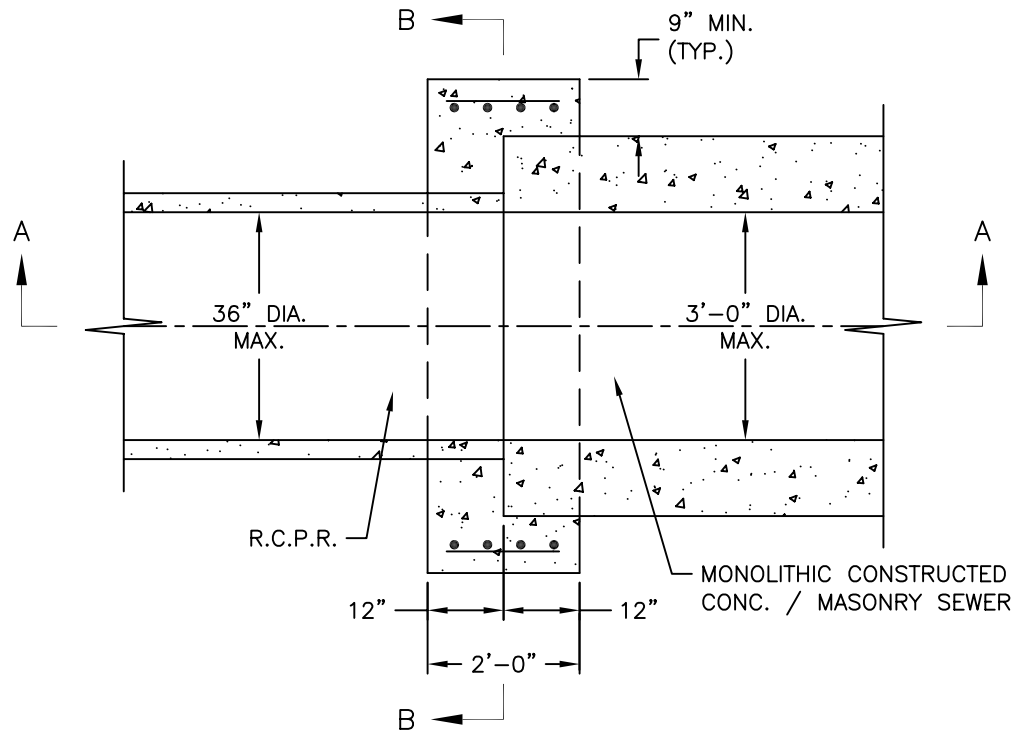

SECTIONAL CONNECTION DETAIL

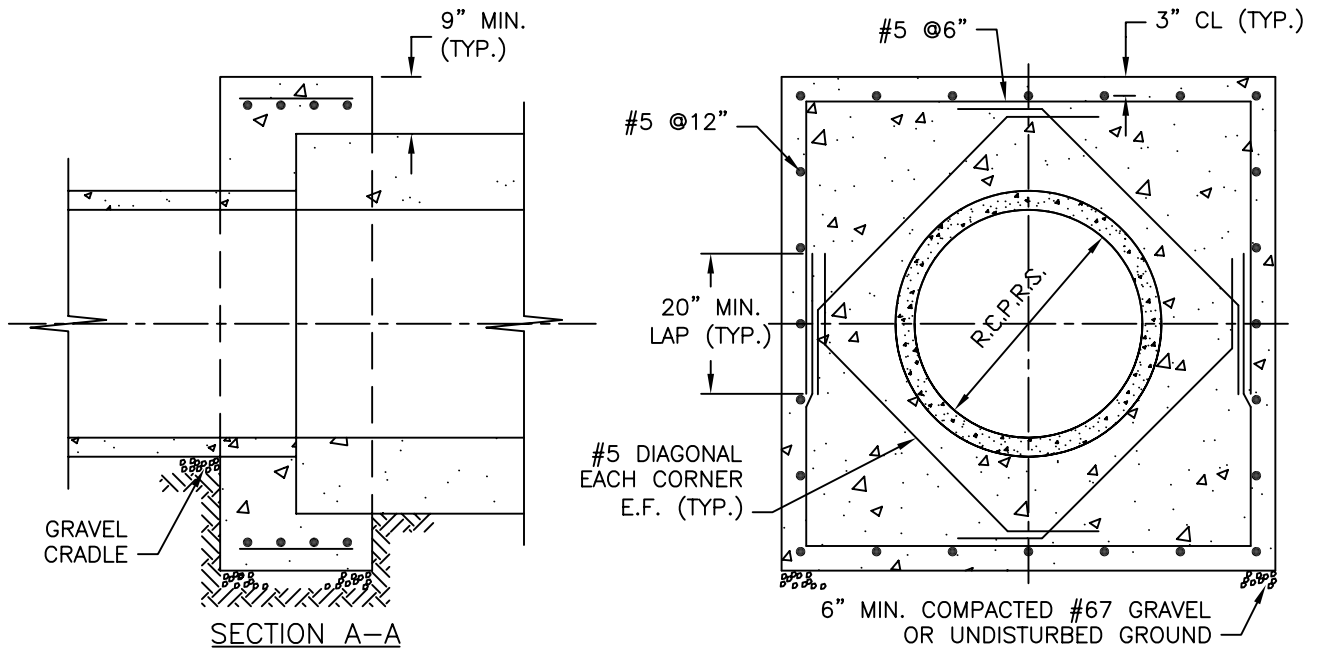

NOTE:

1. ALL CONCRETE TO BE CL. 4000, AIR ENTRAINED, TYPE II CEMENT
2. REINFORCING STEEL SHALL CONFORM TO ASTM A-615, GRADE 60.

APPROVED DATE: June 20, 2003

DIRECTOR, DEPARTMENT OF ENGINEERING
AND TECHNICAL SERVICES

REVISION NO.: 0
DATE: 6/20/03
PREPARED BY: OBG/BKJV
CHECKED BY: W.DARROW

STANDARD DETAIL
REINFORCED CONCRETE PIPE COLLAR
DETAIL - 36" AND SMALLER DIA.

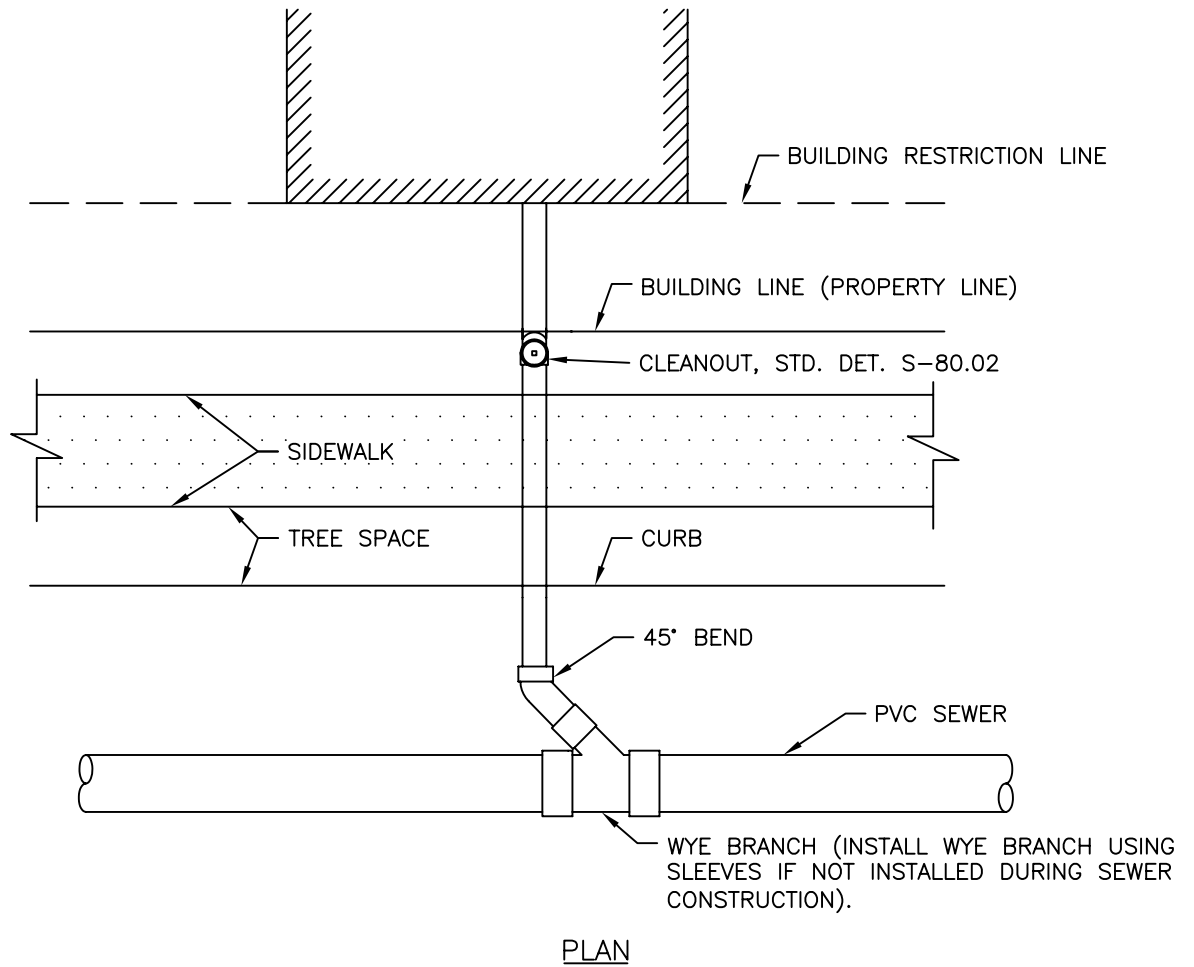

NOTES:

1. MATERIALS AND WORKMANSHIP BETWEEN THE WYE BRANCH AND THE BUILDING MUST BE IN ACCORDANCE WITH D.C. PLUMBING CODE.
2. VERTICAL BENDS FOR GRADE (NOT SHOWN) MAY BE REQUIRED ON SEWER LATERAL.

APPROVED DATE: June 20, 2003

DIRECTOR, DEPARTMENT OF ENGINEERING
AND TECHNICAL SERVICES

REVISION NO.: 0
DATE: 6/20/03
PREPARED BY: OBG/BKJV
CHECKED BY: W.DARROW

STANDARD DETAIL
SEWER LATERAL PLAN
(CONNECTION TO PVC SEWER)

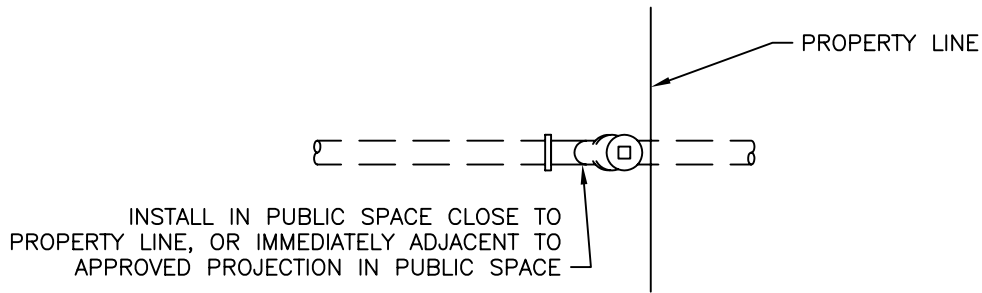

PLAN

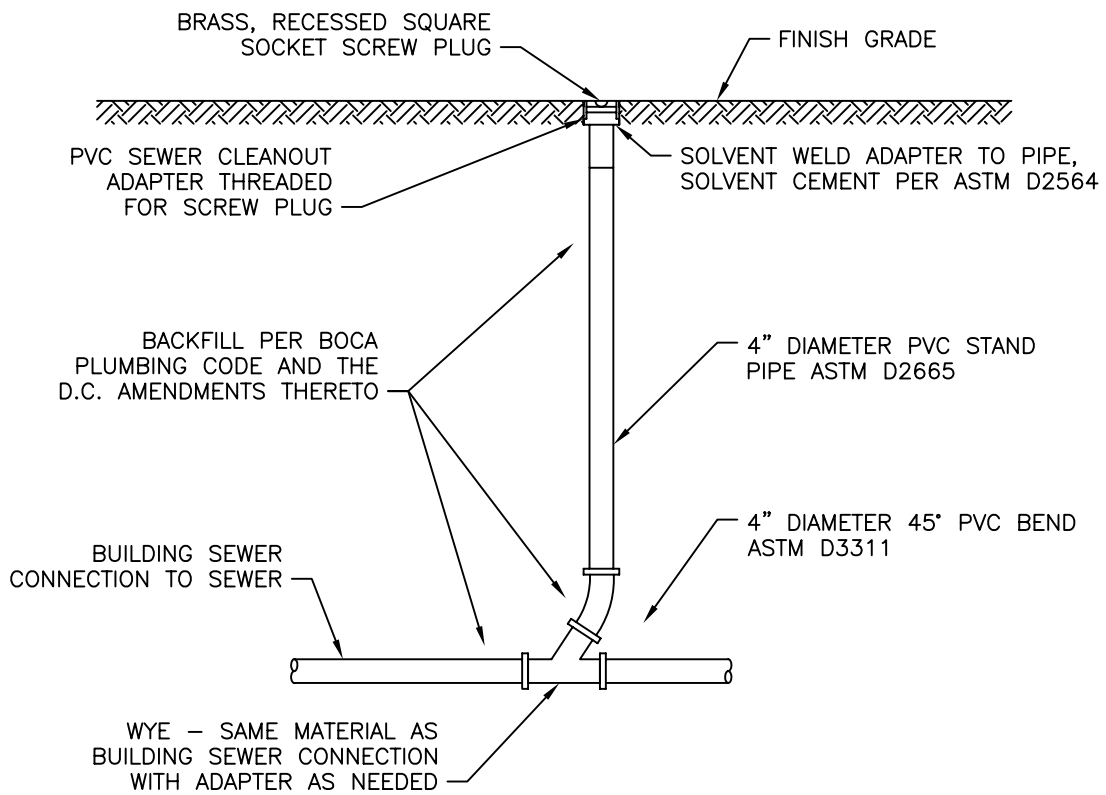

ELEVATION

APPROVED DATE: June 20, 2003

DIRECTOR, DEPARTMENT OF ENGINEERING
AND TECHNICAL SERVICES

REVISION NO.: 0
DATE: 6/20/03
PREPARED BY: OBG/BKJV
CHECKED BY: W.DARROW

STANDARD DETAIL

BUILDING SEWER COLLECTION CLEANOUT

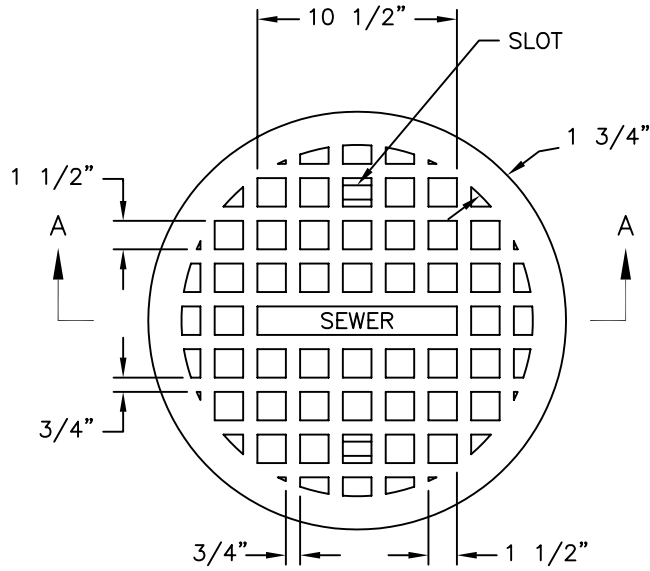

PLAN - COVER

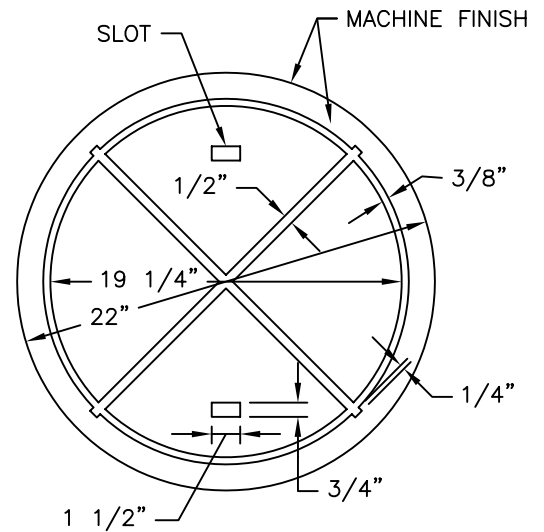

PLAN - COVER BOTTOM

NOTES:

1. GRAY IRON CASTINGS PER ASTM A-48, CLASS 30A.
2. ALL MACHINE FINISH TO BE A.S.A. SPECIFICATION, ROUGHNESS SYMBOL 250, TOLERANCE $-0" +1/16"$.
3. THE WORD "SEWER" IN 1" LETTER SHALL BE CAST IN THE DEPRESSION SHOWN IN THE CENTER OF TOP OF COVER AND TO BE FLUSH WITH SURFACE OF COVER.

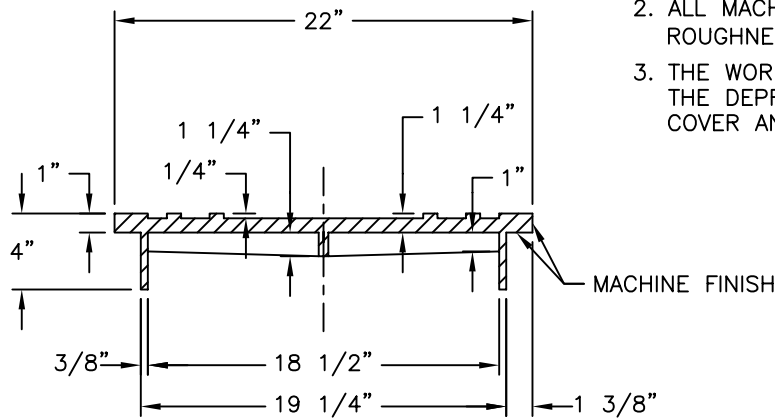

SECTION A-A

APPROVED DATE: June 20, 2003

DIRECTOR, DEPARTMENT OF ENGINEERING
AND TECHNICAL SERVICES

REVISION NO.: 0
DATE: 6/20/03
PREPARED BY: OBG/BKJV
CHECKED BY: W.DARROW

STANDARD DETAIL

DETAILS OF 24" CAST
IRON MANHOLE COVER

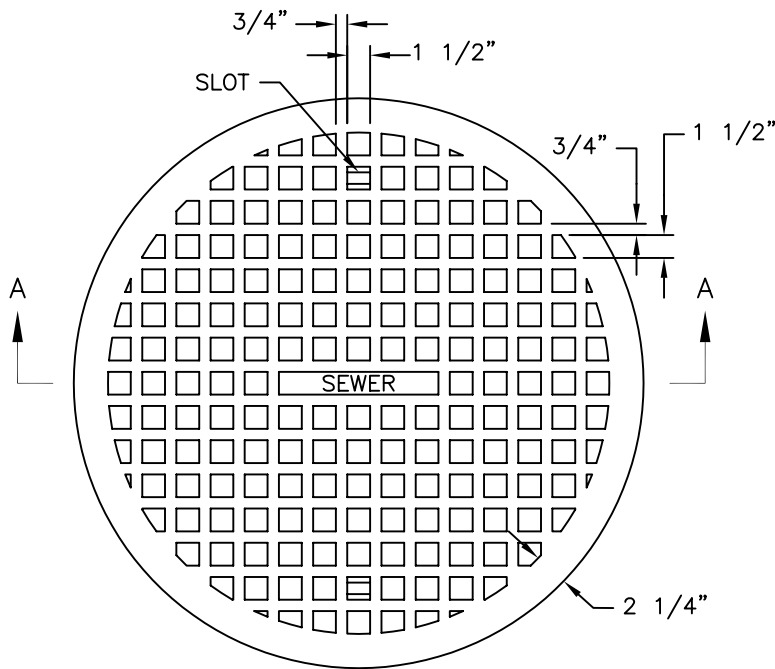

PLAN - COVER

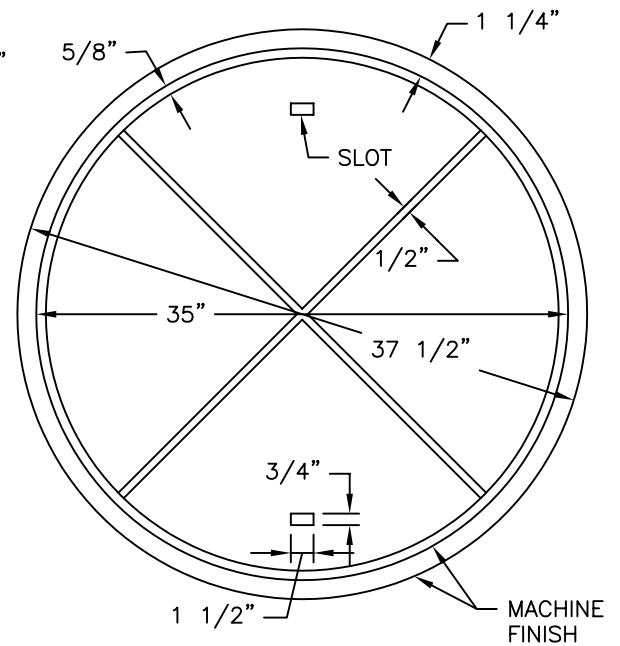

OVER BOTTOM VIEW

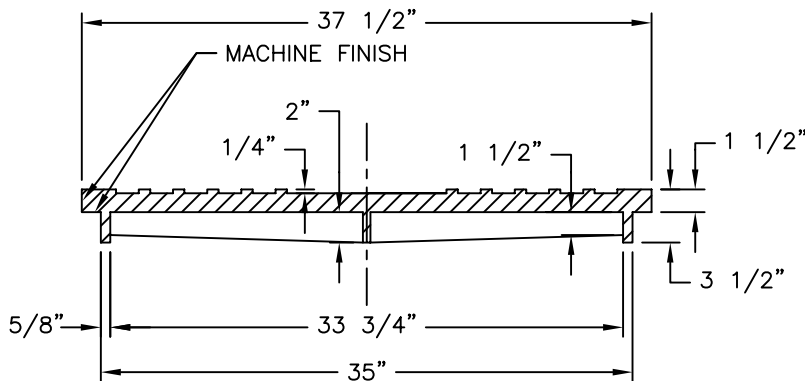

SECTION A-A

NOTES:

1. GRAY IRON CASTINGS PER ASTM A 48, CLASS 30A.
2. ALL MACHINE FINISH TO BE A.S.A. SPECIFICATION, ROUGHNESS SYMBOL 250, TOLERANCE $-0" +1/16"$.
3. THE WORD "SEWER" IN 1" LETTER SHALL BE CAST IN THE DEPRESSION SHOWN IN THE CENTER OF TOP OF COVER AND TO BE FLUSH WITH SURFACE OF COVER.

APPROVED DATE: June 20, 2003

DIRECTOR, DEPARTMENT OF ENGINEERING
AND TECHNICAL SERVICES

REVISION NO.: 0
DATE: 6/20/03
PREPARED BY: OBG/BKJV
CHECKED BY: W.DARROW

STANDARD DETAIL

DETAILS OF 36" CAST IRON MANHOLE COVER

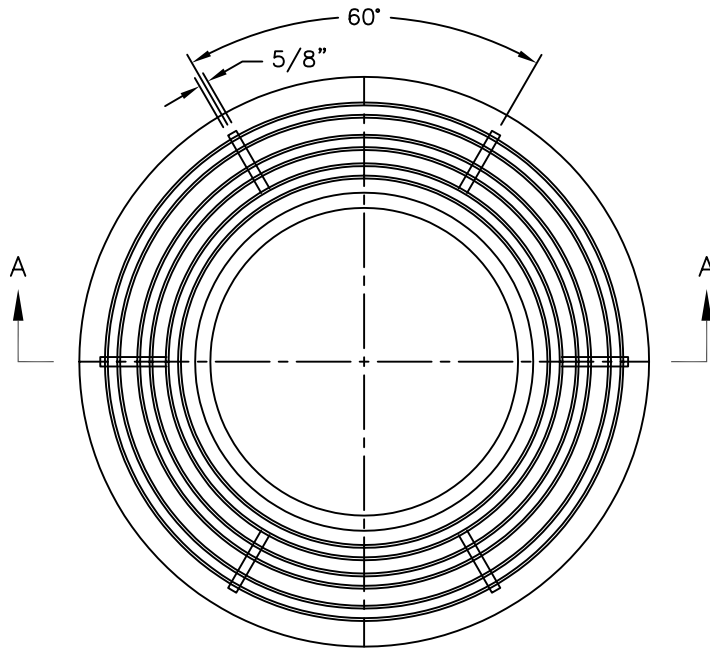

PLAN - ADAPTER RING

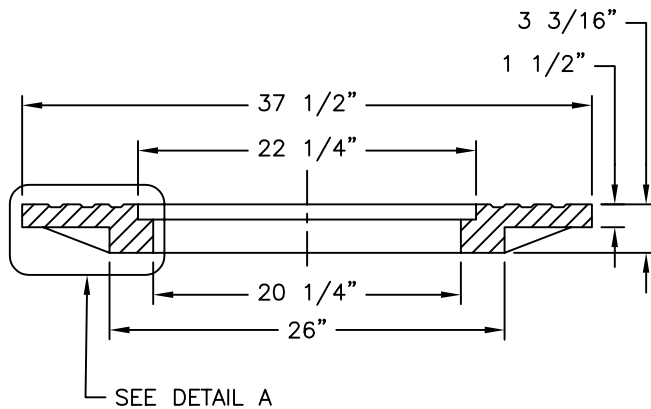

SECTION A-A

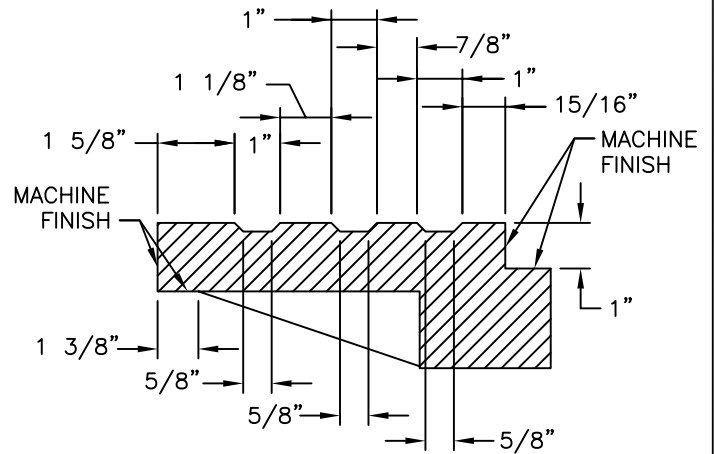

DETAIL A

NOTE:

1. GRAY IRON CASTINGS PER ASTM A48, CLASS 30A.
2. ALL MACHINE FINISH TO BE A.S.A. SPECIFICATION, ROUGHNESS SYMBOL 250, TOLERANCE $-0" +1/16"$.

APPROVED DATE: June 20, 2003

DIRECTOR, DEPARTMENT OF ENGINEERING
AND TECHNICAL SERVICES

REVISION NO.: 0
DATE: 6/20/03
PREPARED BY: OBG/BKJV
CHECKED BY: W.DARROW

STANDARD DETAIL
MANHOLE ADAPTER RING 36" DIA. TO 24" DIA.
FOR USE ON SEWERS 15' OR LESS
IN DEPTH REQUIRING 36" DIAMETER FRAME

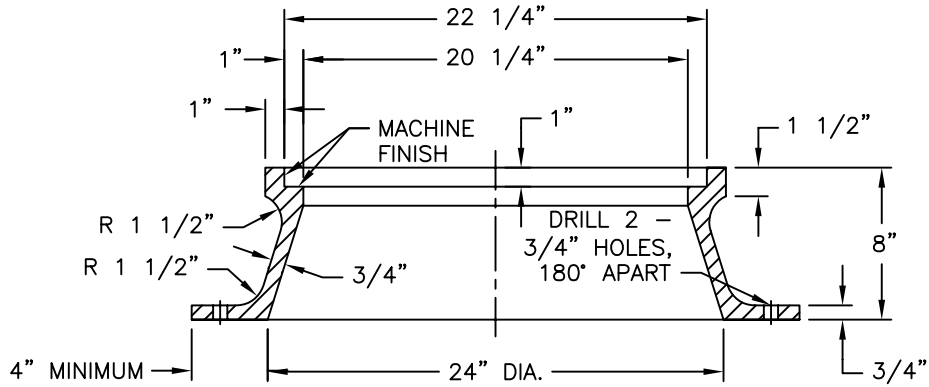

SECTION OF 24-INCH DIAMETER FRAME

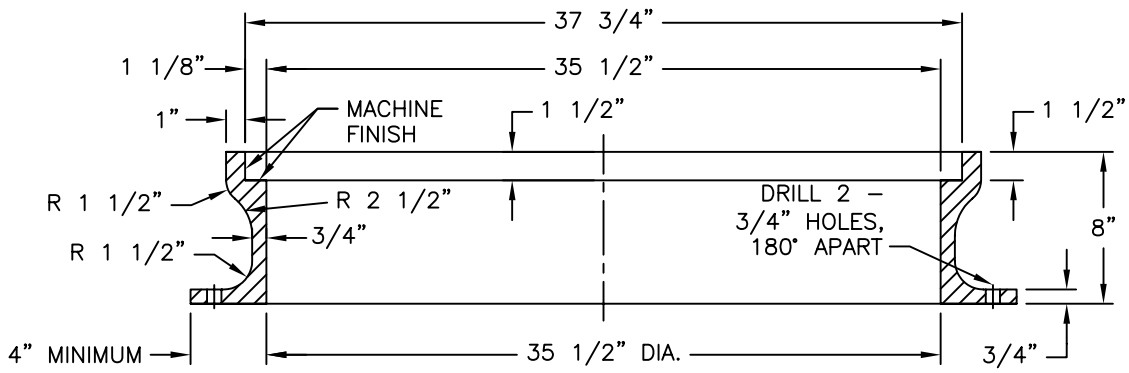

SECTION OF 36-INCH DIAMETER FRAME

NOTE:

1. GRAY IRON CASTINGS PER ASTM A 48, CLASS 30A.
2. ALL MACHINE FINISH TO BE A.S.A. SPECIFICATION, ROUGHNESS SYMBOL 250, TOLERANCE $-0" +1/16"$.

APPROVED DATE: June 20, 2003

DIRECTOR, DEPARTMENT OF ENGINEERING
 AND TECHNICAL SERVICES

REVISION NO.: 0
 DATE: 6/20/03
 PREPARED BY: OBG/BKJV
 CHECKED BY: W.DARROW

STANDARD DETAIL

DETAILS OF 24" & 36" DIAMETER
 CAST IRON FRAMES

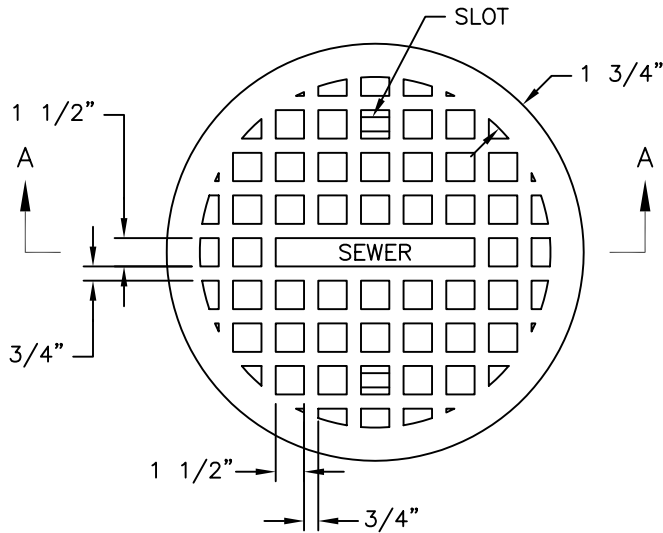

PLAN - COVER

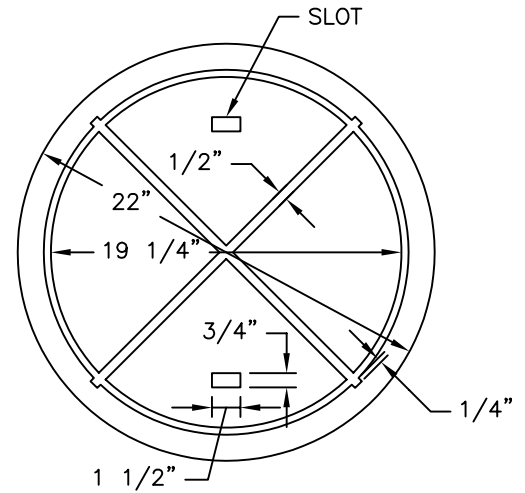

PLAN - COVER BOTTOM

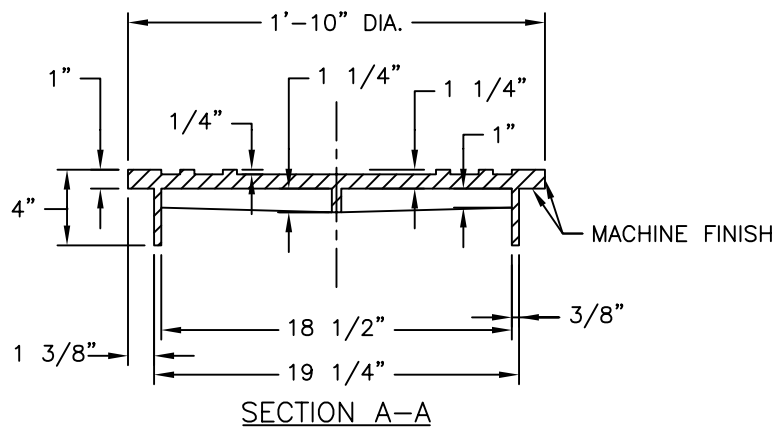

SECTION A-A

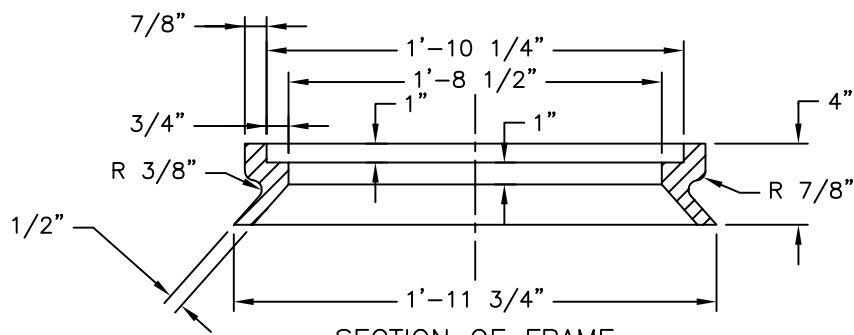

SECTION OF FRAME

NOTES:

1. GRAY IRON CASTINGS PER ASTM A-48, CLASS 30A, OR 35.
2. ALL MACHINE FINISH TO BE A.S.A. SPECIFICATION, ROUGHNESS SYMBOL 250, TOLERANCE -0" +1/16".
3. THE WORD "SEWER" IN 1" LETTERS SHALL BE CAST IN THE DEPRESSION SHOWN IN THE CENTER OF TOP OF COVER AND TO BE FLUSH WITH SURFACE OF COVER.

APPROVED DATE: June 20, 2003

DIRECTOR, DEPARTMENT OF ENGINEERING
AND TECHNICAL SERVICES

REVISION NO.: 0
DATE: 6/20/03
PREPARED BY: OBG/BKJV
CHECKED BY: W.DARROW

STANDARD DETAIL
DETAILS OF 24" CAST IRON
COVER AND FRAME FOR
BASIN TOP